

Tubular Heaters

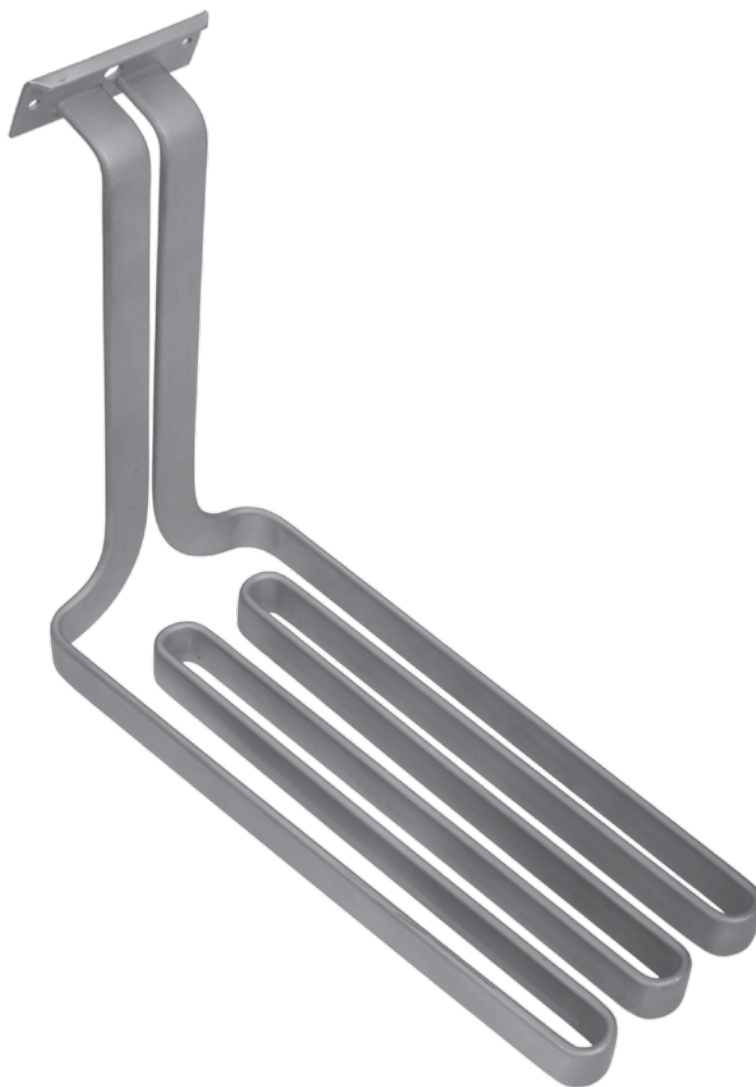

Tubular Heaters	Sheath Materials	Max. Operating Temperatures		Typical Max. Watt Densities		Page
		°F	°C	W/in ²	W/cm ²	
WATROD™ Single-Ended Double-Ended	Alloy 800/840	1600	870	45	6.9	57
	Stainless steel	1200	650	60	9.3	
	Steel	750	400	45	6.9	
	Alloy 600	1800	982	45	6.9	
High-Temperature	Alloy 600	1800	982	45	6.9	80
MULTICOIL™	Alloy 800	1400	760	45	6.9	82
	304 stainless steel	1200	650	45	6.9	
	316 stainless steel	1200	650	45	6.9	
FIREBAR® Single-Ended Double-Ended	Alloy 800/840	1400	760	60	9.3	84
	304 stainless steel	1200	650	60	9.3	
FINBAR™ Single-Ended	304 stainless steel	1200	650	50	7.7	103

Tubular Heaters





Tubular Heaters



WATROD™ Single/Double-Ended Heaters

Available in single- or double-ended termination styles, the versatile and economical WATROD™ tubular heating element from Watlow® lends itself to virtually the entire range of immersion and air heating applications.

The single-ended WATROD tubular design has both terminals at one end. The opposite end is sealed. Flexible lead wires are 12 in. (305 mm) crimp connected to the terminal pin and have silicone-impregnated fiberglass oversleeves.

The double-ended WATROD, with its round cross-sectional geometry, is highly adaptable for bending—especially when bending is performed in the field. Watlow's double-ended MULTICOIL™ tubular elements offer various combinations of resistor coils and thermocouples inside one sheath. They have the ability to sense the heater's internal temperature accurately every time, or offer three-phase capability in one element.

Both single- and double-ended WATRODs share many construction features delivering long life—the resistance wire is centered in the heater sheath and electrically insulated with compacted, high-grade magnesium oxide for superior heating performance.

WATROD heating elements have a variety of mounting and termination options making them highly popular among industrial customers.

Single-Ended WATROD Performance Capabilities

- Watt densities up to 45 W/in² (6.9 W/cm²)
- UL® and CSA component recognition up to 240VAC
- Alloy 800/840 and stainless steel sheath temperatures up to 1200°F (650°C)

Double-Ended WATROD Performance Capabilities

- Watt densities up to 120 W/in² (18.6 W/cm²)
- UL® and CSA component recognition up to 600VAC
- Alloy 800/840 sheath temperatures up to 1600°F (870°C)
- Stainless steel sheath temperatures up to 1200°F (650°C)
- Steel sheath temperatures up to 750°F (400°C)
- Alloy 800 sheath temperatures up to 1800°F (982°C)

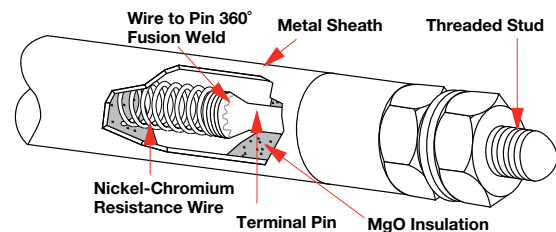
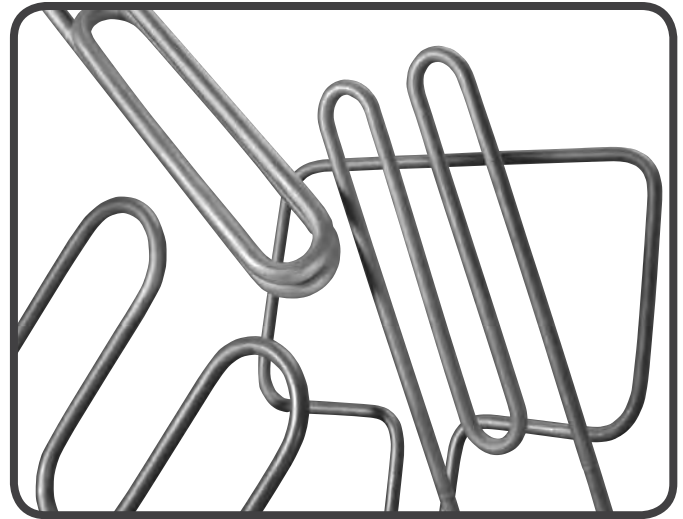

Features and Benefits

Precision wound nickel-chromium resistance wire

- Distributes heat evenly to the sheath for optimum heater performance

Silicone resin seals

- Protects against moisture contamination and is rated to 221°F (105°C)

MgO insulation filled sheath

- Maximizes dielectric strength, heat transfer and life

Standard sheath materials

- Steel, 304 and 316 stainless steel, alloy 800/840 and alloy 600

53 standard bend formations

- Allows forming the heating element to the application. Spirals, compound bends and multi-axis and multi-plane configurations

Stainless steel studs

- Fusion welded to terminal pins for mechanical strength

Popular termination, mounting and moisture seal options available

Tubular Heaters



WATROD Single/Double-Ended Heaters

Specifications

Double-Ended

Single-Ended



Applications	Direct immersion Hot runner mold (manifold) Forced air Ovens Radiant Clamp-on	Vacuums Semiconductor	Platens Forced air Deicing antennas Plastic wrap cutting Seal bars
Watt Density W/in ² (W/cm ²)	Catalog P/N: Standard:	up to 60 (9.3) up to 120 (18.6)	Catalog P/N: Standard:
			up to 20 (3.1) up to 45 (6.9)
Element Diameters in. (mm) and Surface Area per Linear in ² (cm ²) Diameter Tolerance ± 0.005 in. (0.13 mm)	Dia. 0.210 0.260 0.315 0.375 0.430 0.475	in² 0.660 0.817 0.990 1.178 1.351 1.492	Dia. (mm) (5.33) (6.60) (8.00) (9.53) (10.92) (12.07)
			cm² (4.26) (5.27) (6.38) (7.60) (8.72) (9.63)
Sheath Materials Max. Operating Temperature	Standard:	Alloy 800/840 316 SS Steel 304 SS Alloy 600	1600°F (870°C) 1200°F (650°C) 750°F (400°C) 1200°F (650°C) 1800°F (980°C)
	Standard:	Alloy 800/840 316 SS 304 SS	1200°F (650°C) 1200°F (650°C) 1200°F (650°C)
Sheath Length By Diameter in. (mm)	Dia. Standard:	Sheath Length (in.) 9 to 130 9 to 270 9 to 270 11 to 360 11 to 360 11 to 275	Sheath Length (mm) (5.33) (230 to 3300) (6.60) (230 to 6858) (8.00) (230 to 6858) (9.53) (280 to 9144) (10.92) (280 to 9144) (12.07) (280 to 6985)
			Sheath Length (mm) (9.53) (280 to 3175) (10.92) (280 to 2690) (12.07) (280 to 3175)
Min. No-Heat Length in. (mm)	Sheath Length	No-Heat Length	Sheath Length
	11 to 20 21 to 50 51 to 80 81 to 110 111 to 140 141 to 170 171 to 200 201 & up	1 1 ¹ / ₄ 1 ¹ / ₂ 1 ⁵ / ₈ 1 ³ / ₄ 2 2 ¹ / ₄ 2 ¹ / ₂	(280 to 510) (25) (535 to 1270) (32) (1295 to 2030) (38) (2055 to 2795) (42) (2820 to 3555) (44) (3580 to 4320) (51) (4345 to 5080) (57) (5105 & up) (64)
			11 to 20 (1 ¹ / ₂) (280 to 5100) (38) 21 to 50 (1 ³ / ₄) (533 to 1270) (44) 51 to 80 (2 ¹ / ₈) (1295 to 2030) (54) 81 to 110 (2 ³ / ₈) (2055 to 2795) (60) 111 to 125 (2 ⁵ / ₈) (2820 to 3175) (67)
Max. Voltage/Amperage By Dia. in. (mm)	Dia. 0.260 (6.6) 0.315 (8.0) 0.375 (9.53) 0.430 (10.92) 0.475 (12.07)	Volts 250VAC 480VAC 480VAC 600VAC 600VAC	Amperes 15 30 30 40 40
			Dia. 0.375 (9.53) 0.430 (10.92) 0.475 (12.07)
			Volts 480VAC 480VAC 480VAC
			Ampere 30 30 30
			½ in. (13 mm) No-heat length on all blunt ends

Tubular Heaters



WATROD Single/Double-Ended Heaters

Specifications (Continued)

Double-Ended

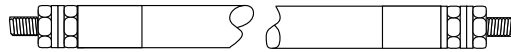

Single-Ended



Ohms Per Heated Inch By Dia. in.	Double-Ended			Single-Ended		
	Dia.	Min.	Max.	Dia.	Min.	Max.
0.210	0.130Ω	14Ω		0.375	0.150Ω	25Ω
0.260	0.080Ω	16Ω		0.430	0.150Ω	24Ω
0.315	0.050Ω	25Ω		0.475	0.150Ω	22Ω
0.375	0.030Ω	20Ω				
0.430	0.030Ω	25Ω				
0.475	0.035Ω	25Ω				
Terminations	Standard:	Threaded stud Screw lug (plate) Quick connect (spade) Flexible lead wires		Standard:	Flexible lead wires	
Seals	Standard:	Silicone resin 221°F (105°C) Ceramic base 2800°F (1535°C) Ceramic-to-metal 482°F (250°C) Silicone rubber (RTV) 392°F (200°C) Silicone resin 392°F (200°C) Epoxy resin 194/356°F (90/180°C)		Standard:	Silicone resin 221°F (105°C) Silicone rubber (RTV) 500°F (260°C) Epoxy resin 194/356°F (90/180°C)	
Mounting Options		Threaded bulkheads Mounting brackets Locator washers			Threaded bulkhead Locator washers Single leg bracket	
Surface Finish Options		Oxide anneal Bright anneal Passivation			Oxide anneal Bright anneal Passivation	
Agency Recognition		UL® component to 480VAC (File # E52951/E56488) CSA component to 600VAC (File # 31388)			UL® component to 240VAC (File # E52951) CSA component to 240VAC (File # 31388) ①	

① Not applicable to 0.375 inch diameter single-ended WATROD.

Tubular Heaters



WATROD Single/Double-Ended Heaters

Options

Moisture Resistant Seals

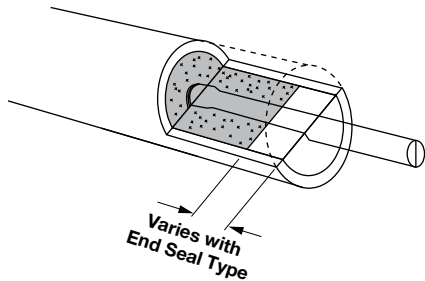

WATROD's MgO insulating material is hygroscopic. To control the rate of moisture entering the heater, an appropriate moisture seal must be used. Choosing the correct seal is important to the life and performance of the heater. All materials have varying rates of gas vapor transmission. Be sure the maximum continuous use temperature is not exceeded at the seal location. Most end seals are applied with a small cavity in the end of the heater. The seal will also help prevent arcing at the terminal ends.

Zoned Heaters

Single zone heaters are only available.

End-Seal Options

End-Seal	Color	UL® Recognition	Max. Cont. Use Temperature	Typical or General Usage/Application
Standard Epoxy	Cream	Yes	194°F (90°C)	Long term stable insulation resistance
Intermediate Epoxy	Gray	Yes	356°F (180°C)	Long term stable insulation resistance
High-Temp. Epoxy	Amber	No	450°F (232°C)	Long term stable insulation resistance
Silicone Resin	Clear	Yes	221°F (105°C)	General usage on tubular products - porous
Silicone Fluid	Clear	Yes	392°F (200°C)	Moisture resistance of the MgO, or high temperature ceramic seal (storage only) - porous
Lavacone	Dark Brown	Yes	221°F (105°C)	Porous seal for the FIREBAR
Silicone Rubber RTV	Red-Orange	Yes	392°F (200°C)	General usage on FIREBAR applications - porous
High-Temperature Ceramic	White	Yes	2800°F (1538°C)	Very high-temperature applications - for extremely low vapor transmission rate

External Finishes

Bright Annealing

Bright annealing is a process that produces a smooth, metallic finish. It is a special annealed finish created in a non-oxidizing atmosphere. This finish is popular in the pharmaceutical and food and beverage markets.

To order, specify **bright annealing**.

Passivation

During the manufacturing process, particles of iron or tool steel may become embedded in the stainless steel or alloy sheath. If not removed, these particles may corrode, produce rust spots and/or contaminate the process. For critical sheath applications, passivation will remove free iron from the sheath.

To order, specify **passivation**.

Tubular Heaters



WATROD Single/Double-Ended Heaters

Terminations

Double-ended WATROD elements are available with a variety of terminations. Single-ended WATROD elements are available with only flexible lead wires.

The following table and illustrations detail the terminations available with double- or single-ended WATRODs—for each available sheath diameter.

Flexible lead wires are 12 in. (305 mm), Sil-A-Blend® 390°F (200°C) unless otherwise specified. Insulation options include TGGT 480°F (250°C) plus other temperature ratings. Contact your Watlow representative.

WATROD Element	Sheath Diameter		Threaded Stud ①	Screw Lug (Plate)				Quick Connect (Spade)			Flexible Lead Wires
	in.	(mm)	A	B	C	D	E	F	G	H	
Double-Ended	0.260	(6.6)	#6-32	Yes	Yes	Yes	Yes	Yes	Yes	Yes	Yes
	0.315	(8.0)	#10-32	Yes	Yes	Yes	Yes	Yes	Yes	Yes	Yes
	0.375	(9.5)	#10-32	Yes	Yes	Yes	Yes	Yes	Yes	Yes	Yes
	0.430	(10.9)	#10-32	Yes	Yes	Yes	Yes	Yes	Yes	Yes	Yes
	0.475	(12.1)	#10-32	Yes	Yes	Yes	Yes	Yes	Yes	Yes	Yes
Single-Ended	0.375	(9.53)	No	No	No	No	No	No	No	No	Yes
	0.430	(10.9)	No	No	No	No	No	No	No	No	Yes
	0.475	(12.1)	No	No	No	No	No	No	No	No	Yes

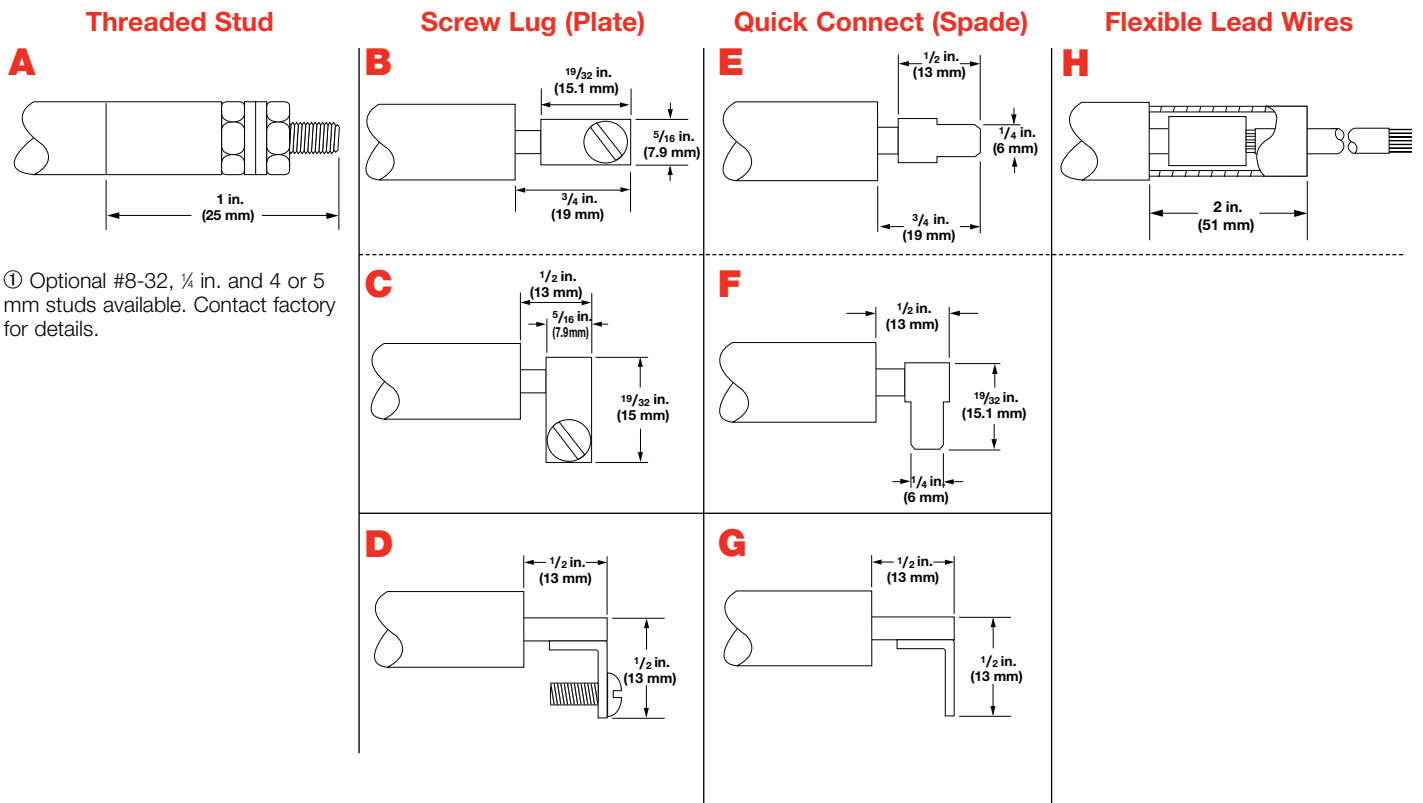



WATROD Single/Double-Ended Heaters

Bend Formations

Double-Ended WATROD Bend Formations

Double-ended WATROD heating elements can be formed into spirals, compounds, multi-axis and multi-planes from 36 common bend configurations. Custom bending with tighter tolerances can be made to meet specific application needs.

Formation is limited by the minimum bend radius (R) and the straight length (F) required beyond the bend. In order to locate the end of a heated length within a bend, the radius must be 3 in. (76 mm) or larger. Additionally, overall length tolerance (T) must be included in one or more of the straight lengths.

Minimum radius for various sheath diameters and lengths are shown in the *Bend Formations* chart below. Illustrated on pages 62 to 71 are the 56 common bend configurations available on both standard and made-to-order WATROD heating elements.

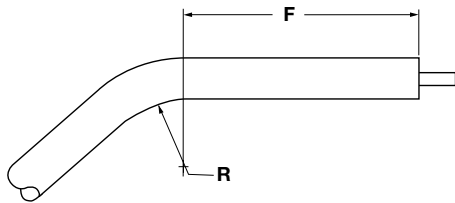

Single-Ended WATROD Bend Formations

Watlow does not recommend field bending single-ended WATROD elements. Formation is limited by the minimum radius of a bend (R) and the straight length (F) beyond the bend. The radius must be 3 in. (75 mm) or more for the heated length's end to be inside a bend.

Additionally, the overall length tolerance (T) must be provided for in one or more of the specified lengths.

The four common bend configurations available for standard and made-to-order single-ended WATROD elements are Figures 1, 6, 22 and 28.

To order a common bend formation, specify the **bend figure number**, dimensions and critical tolerances.

WATROD Minimum Radius				
Sheath Diameter in. (mm)	Field Bend R ^① in. (mm)	Factory R ^① in. (mm)	F ^② Dimension in. (mm)	
0.260 (6.6)	3/4 (19.0)	3/8 (9.5)	1/2 (13.0)	
0.315 (8.0)	3/4 (19.0)	1/2 (13.0)	1/2 (13.0)	
0.375 (9.52)	1 (25.0)	1/2 (13.0)	1/2 (13.0)	
0.430 (10.92)	1 (25.0)	1/2 (13.0)	3/4 (19.0)	
0.475 (12.07)	1 (25.0)	5/8 (15.9)	1 (25.0)	

① R is the inside radius of a bend.

② F is the distance from the sheath's end to the start of the first bend.

WATROD Length Tolerance (T)			
Sheath Length in. (mm)	Length Tolerance in. (mm)	Sheath Length in. (mm)	Length Tolerance in. (mm)
11-50 (280-1270)	±1/8 (±3)	51-110 (1295-2795)	±3/16 (±5)
111-170 (2820-4320)	±1/4 (±6)	171-200 (4345-5080)	±3/8 (±10)
201 & up (5105 & up)	±1/2 (±13)		

Figure 1

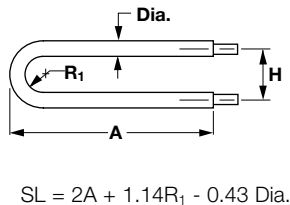
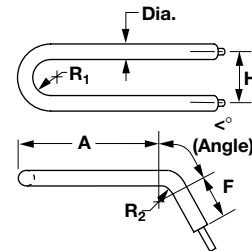

Figure 2



Tubular Heaters



WATROD Single/Double-Ended Heaters

Bend Formations (Continued)

Figure 3

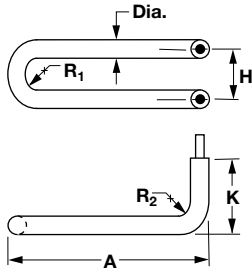

$$SL = 2K - 0.86R_2 - 2.86 \text{ Dia.} + 2A + 1.14R_1$$

Figure 5

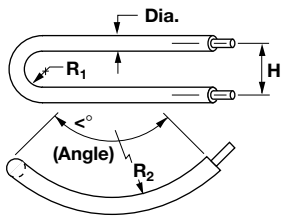

$$SL = 0.0175(\angle) (2R_2 + \text{Dia.}) + 1.14R_1 + 0.43 \text{ Dia.}$$

Figure 7

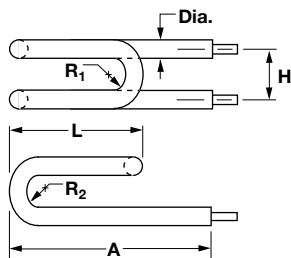

$$SL = 2A + 2.28R_2 - 1.29 \text{ Dia.} + 2L + 1.14R_1$$

Figure 4

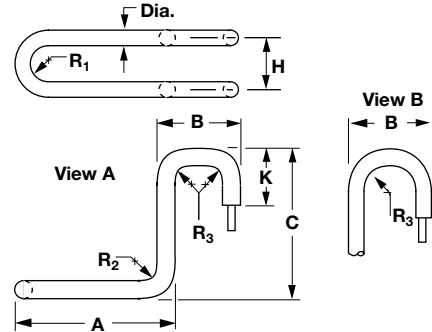

$$\text{View A: } SL = 2K - 1.72R_3 - 7.72 \text{ Dia.} + 2C - 0.86R_2 + 2A + 1.14R_1$$

$$\text{View B: } SL = 2K - 2.28R_3 - 3.72 \text{ Dia.} + 2C - 0.86R_2 + 2A + 1.14R_1$$

Figure 6

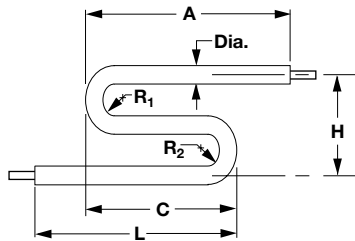

$$SL = L + 1.14R_2 - 0.86 \text{ Dia.} + C + 1.14R_1 + A$$

Figure 8

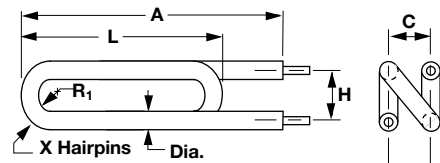

X = number of outside hairpins

$$SL = 2A + 3.42R_1 - 1.29 \text{ Dia.} + 2L$$

Figure 8 Reverse

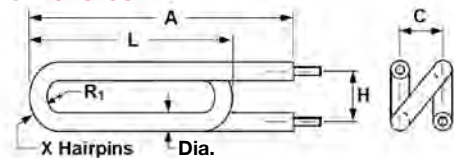

Tubular Heaters



WATROD Single/Double-Ended Heaters

Bend Formations (Continued)

Figure 9

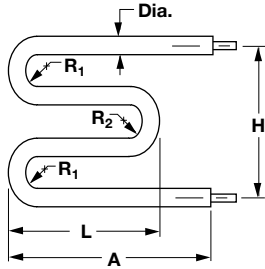

$$SL = 2A + 2.28R_1 - 1.29 \text{ Dia.} + 2L + 1.14R_2$$

Figure 10

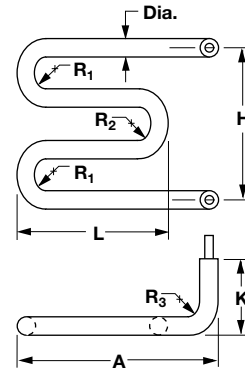

$$SL = 2K - 0.86R_3 - 3.72 \text{ Dia.} + 2A + 2L + 2.28R_1 + 1.14R_2$$

Figure 11

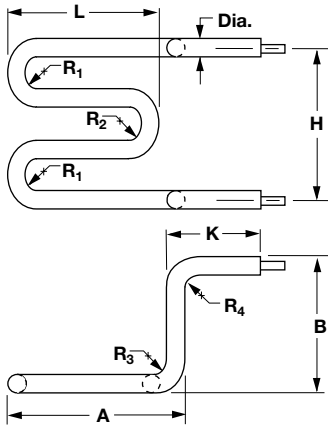

$$SL = 2K - 0.86R_3 - 0.86R_4 - 6.15 \text{ Dia.} + 2B + 2A + 2L + 2.28R_1 + 1.14R_2$$

Figure 12

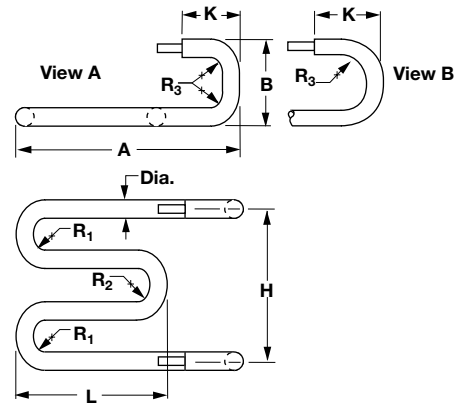

$$\begin{aligned} \text{View A: } SL &= 2K + 2B + 2A + 2L + 2.28R_1 + 1.14R_2 - 1.72R_3 - 6.15 \text{ Dia.} \\ \text{View B: } SL &= 2K + 2A + 2L + 2.28R_1 + 1.14R_2 - 2.28R_3 - 2.15 \text{ Dia.} \end{aligned}$$

Figure 13

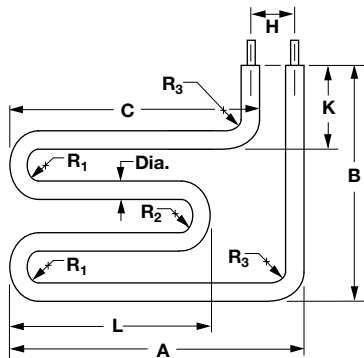

$$SL = 2B + 2A + 2L - 6.717 \text{ Dia.} - 1.717R_1 - H - 0.858R_2 - 0.858R_3$$

Figure 14

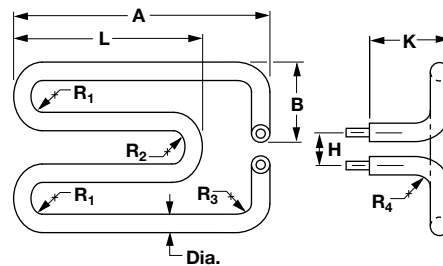

$$SL + 2K + 2A + 2L + 2.28R_1 + 1.14R_2 + 2B - 6.15 \text{ Dia.} - 0.86R_3 + 0.86R_4$$

Tubular Heaters



WATROD Single/Double-Ended Heaters

Bend Formations (Continued)

Figure 15

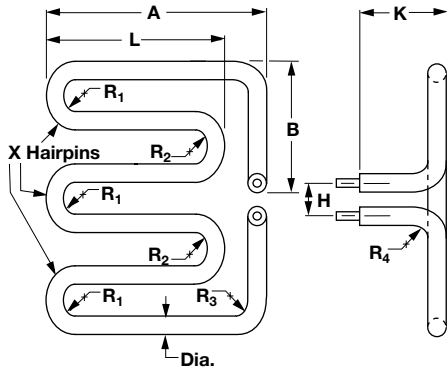

X = number of outside hairpins
 $SL = 2K + 2A + 2K(X - 1) + 2B - 0.86R_3 - 0.86R_4 + 1.14R_1(X) + 1.14R_2(X - 1) - 4.86 \text{ Dia.} - (2X - 1) 0.43 \text{ Dia.}$

Figure 16

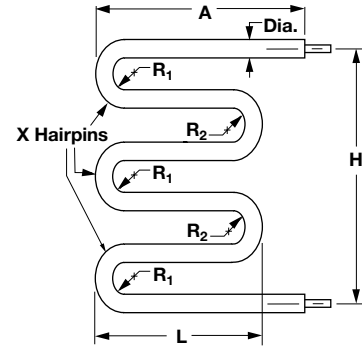

X = number of outside hairpins
 $SL = 2A + 0.43 \text{ Dia.} (1 - 2X) + 2L(X - 1) + 1.14R_1 + 1.14R_2(X - 1)$

Figure 17

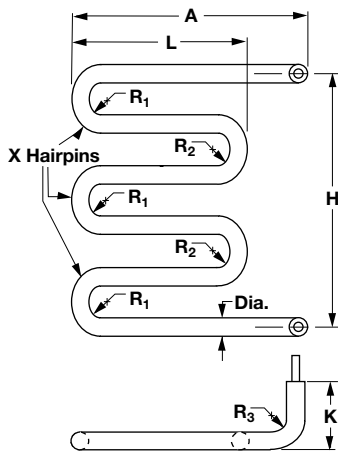

X = number of outside hairpins
 $SL = 1.14R_2X - 0.88 \text{ Dia.} X - 1.14R_2 - 2 \text{ Dia.} + 1.14R_1 X - 0.86R_3 + 2L X - 2L + 2A + 2K$

Figure 18

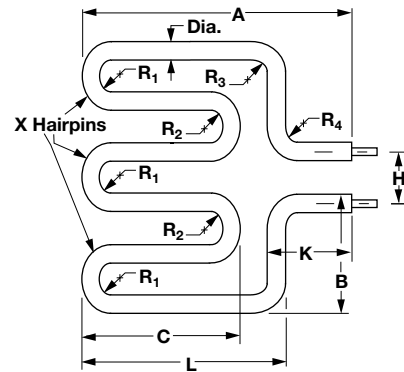

X = number of outside hairpins
 $SL = 2L + 2K + 2B + 2C(X - 1) - 0.86R_3 - 0.86R_4 - 4.86 \text{ Dia.} + 1.14R_1(X) + 1.14R_2(X - 1) - (2X - 1) 0.43 \text{ Dia.}$

Tubular Heaters



WATROD Single/Double-Ended Heaters

Bend Formations (Continued)

Figure 19

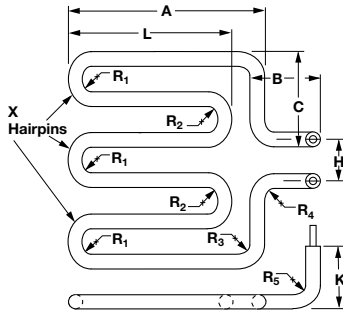

$$\begin{aligned}
 X &= \text{number of outside hairpins} \\
 SL &= 2K + 2A + 2B + 2C + 2L(X - 1) + 1.14R_1 \\
 &\quad (X) + 1.14R_2(X - 1) - 0.86R_3 - 0.86R_4 \\
 &\quad - 0.86R_5 - 7.29 \text{ Dia.} - (2X - 1) 0.43 \text{ Dia.}
 \end{aligned}$$

Figure 20

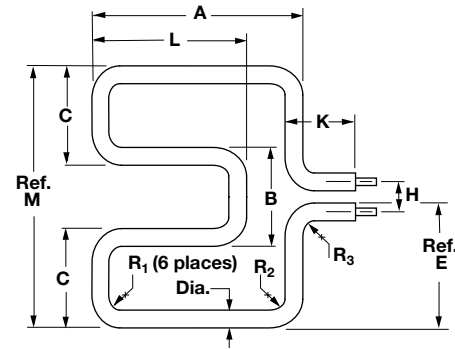

$$\begin{aligned}
 SL &= 2K + 2C + B + 2A + 2L - 2.58R_1 - 0.86R_2 - \\
 &\quad 0.86R_3 - 12.15 \text{ Dia.}
 \end{aligned}$$

Figure 21

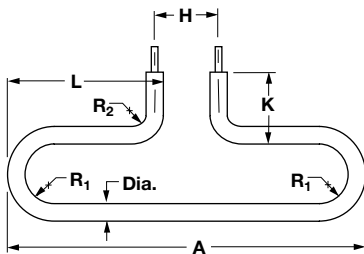

$$\begin{aligned}
 SL &= 2A + 2K - H - 2.28R_1 - 0.86R_2 \\
 &\quad - 3.29 \text{ Dia.}
 \end{aligned}$$

Figure 22

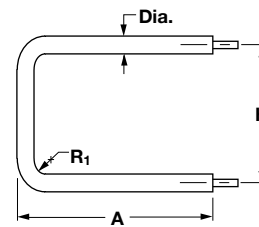

$$\begin{aligned}
 SL &= 2A - 0.86R_1 - 1.43 \text{ Dia.} + H
 \end{aligned}$$

Figure 23

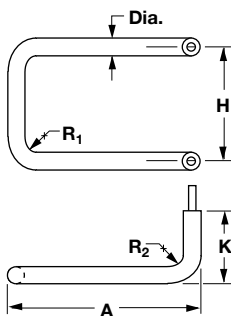

$$\begin{aligned}
 SL &= 2K - 0.86R_2 - 3.86 \text{ Dia.} + 2A - 0.86R_1 + H
 \end{aligned}$$

Figure 24

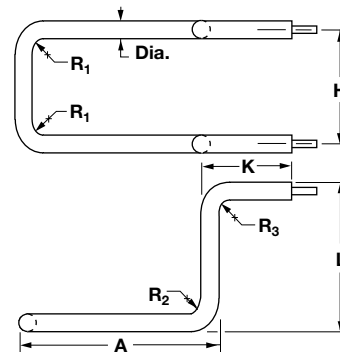

$$\begin{aligned}
 SL &= 2K + 2L + H - 0.86R_1 - 0.86R_2 - 0.86R_3 \\
 &\quad - 7.29 \text{ Dia.}
 \end{aligned}$$

Tubular Heaters



WATROD Single/Double-Ended Heaters

Bend Formations (Continued)

Figure 25

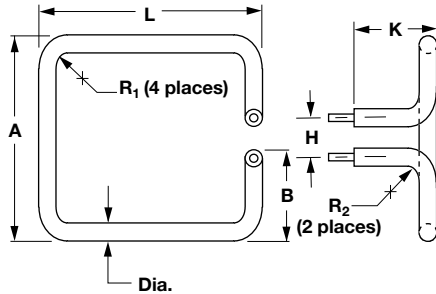

$$SL = 2K + 2A + 2L - H - 1.72R_1 - 0.86R_2 - 6.92 \text{ Dia.}$$

Figure 26

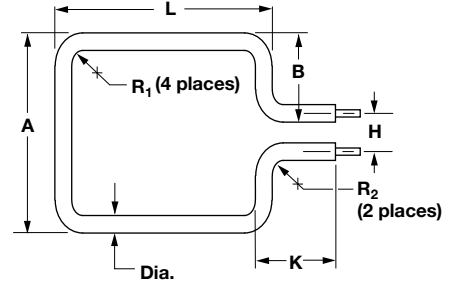

$$SL = 2K + 2A + 2L - H - 1.72R_1 - 0.86R_2 - 6.29 \text{ Dia.}$$

Figure 27

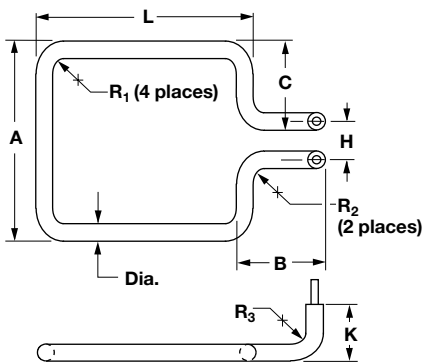

$$SL = 2K + 2A + 2L + 2B - H - 1.72R_1 - 1.72R_2 - 8.72 \text{ Dia.}$$

Figure 28

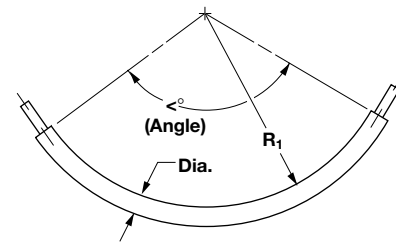

$$SL = 0.0175 \angle^\circ (R_1 + 0.5 \text{ Dia.})$$

Figure 29

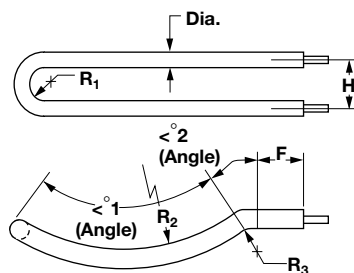

$$SL = 0.0175 \angle^{\circ 1} (2R_2 + \text{Dia.}) + 2F + 1.14R_1 + 0.0175 \angle^{\circ 2} (2R_3 + \text{Dia.}) - 0.43 \text{ Dia.}$$

Figure 30

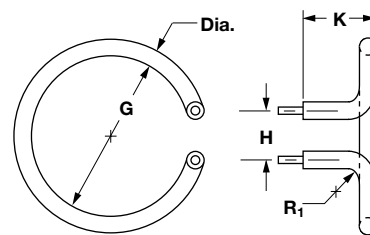

$$SL = (G + \text{Dia.}) 3.14 + 1.14R_1 + 2K + 3.28 \text{ Dia.} - H$$

Tubular Heaters



WATROD Single/Double-Ended Heaters

Bend Formations (Continued)

Figure 31

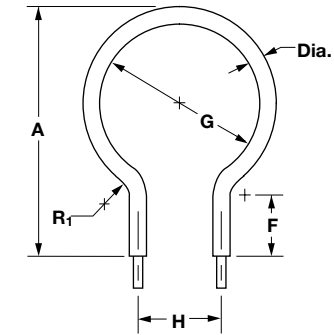

$$SL = (G + \text{Dia.}) 3.14 + 1.14R_1 + 2F + 3.71 \text{ Dia.} - H$$

Figure 32

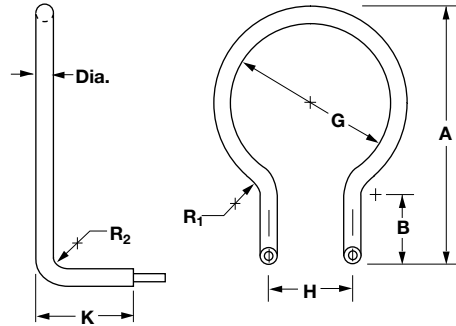

$$SL = (G + \text{Dia.}) 3.14 + 1.14R_1 + 2B + 1.14R_2 + 2K + 3.28 \text{ Dia.} - H$$

Figure 37

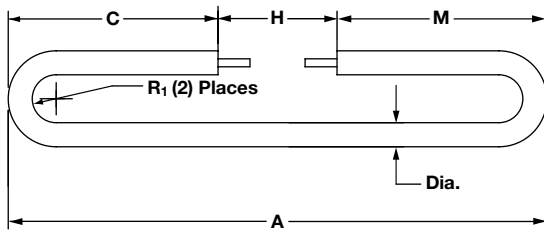

$$SL = (2A - H) + 2\pi R_1 - 2R_1$$

Figure 38

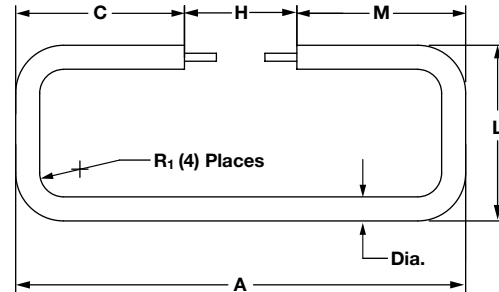

$$SL = (2A - H) + 2L + 2\pi R_1 - 4R_1$$

Figure 39

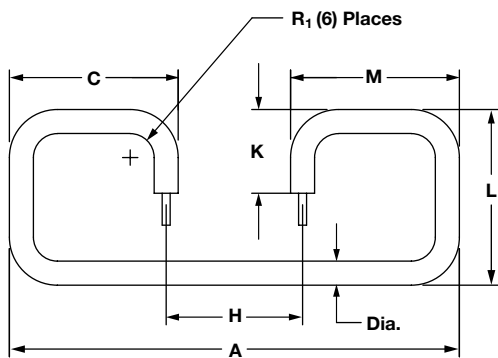

$$SL = (2A - H) + 2L + 2K + 3\pi R_1 - 6R_1$$

Figure 40

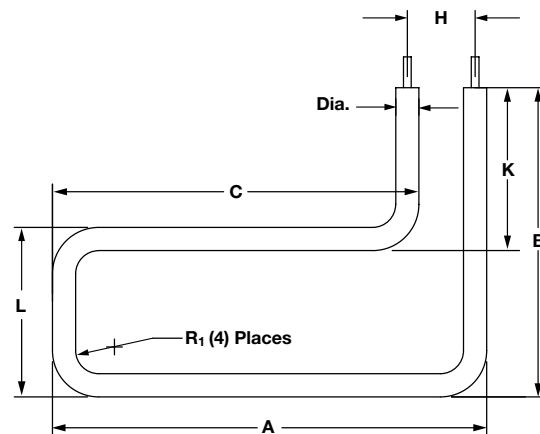

$$SL = (2A - H) + 2B + 2\pi R_1 - 4R_1$$

Tubular Heaters



WATROD Single/Double-Ended Heaters

Bend Formations (Continued)

Figure 41

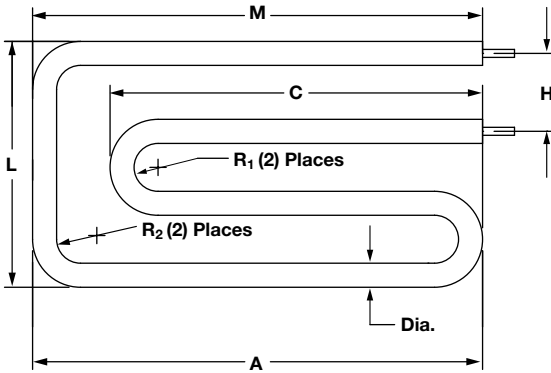

$$SL = 2A + 2C + L - H + 2\pi R_1 + \pi R_2 - 2R_1 \cdot 2R_2$$

Figure 42

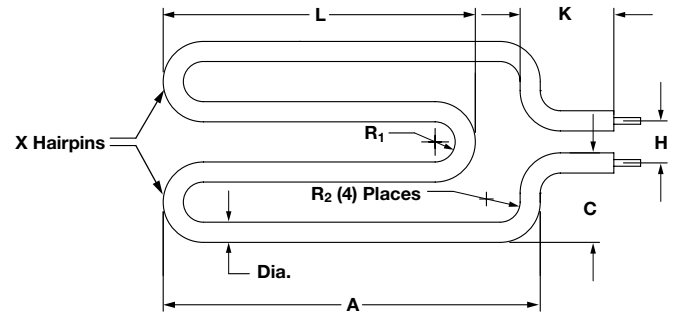

$$SL = 2A + (\#)L + 2K + 2C + 2\pi R_2 + (\# \text{ of } R_1) \pi R_1 - (\# \text{ of } R_1) R_1$$

Figure 43

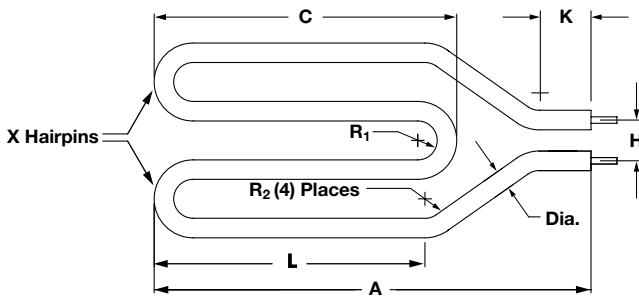

$$SL = 2A + (\#)C + (\# \text{ of } R_1) \pi + 2\pi R_2 - (\# \text{ of } R_1) R_1 - 4R_2$$

Figure 44

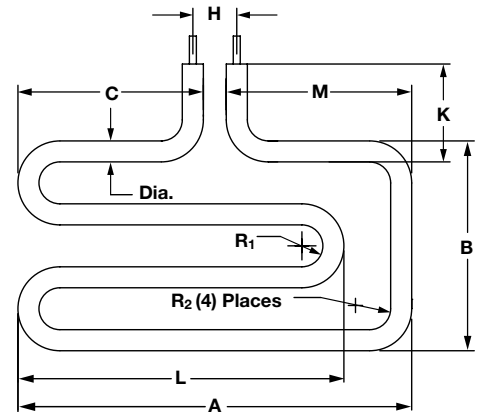

$$SL = 2A + 2L + B + 2K + 2\pi R_2 + 3\pi R_1 - 4R_2 - 3R_1$$

Figure 45

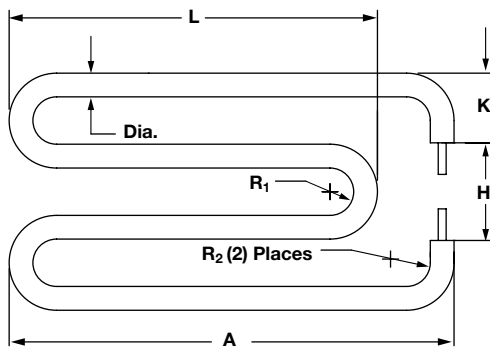

$$SL = 2A + 2L + 2K + 3\pi R_1 + \pi R_2 - 3R_1 - 2R_2$$

Figure 46

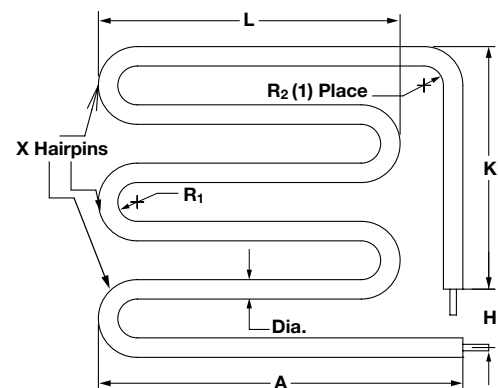

$$SL = 2A + (\#)L + K + (\# \text{ of } R_1) \pi + \pi R_2 - (\# \text{ of } R_1) R_1 - R_2$$

Tubular Heaters



WATROD Single/Double-Ended Heaters

Bend Formations (Continued)

Figure 47

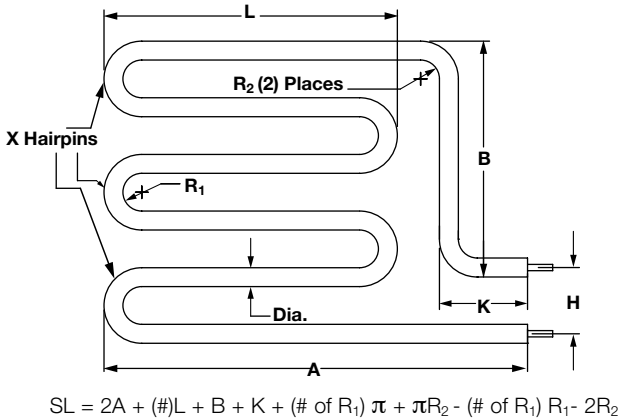

Figure 48

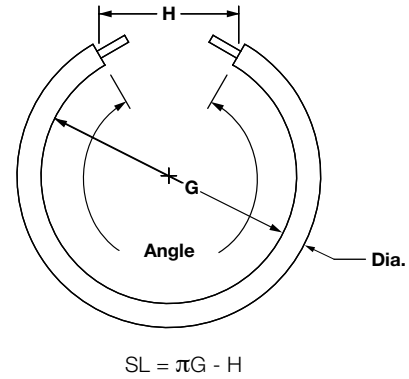

Figure 49

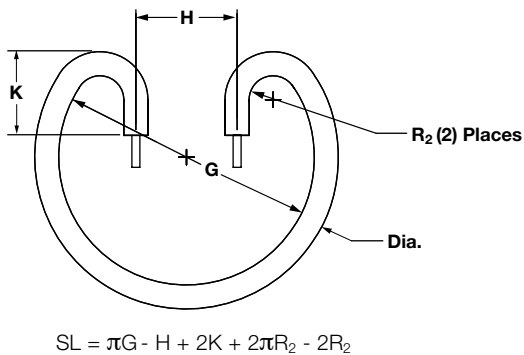

Figure 50

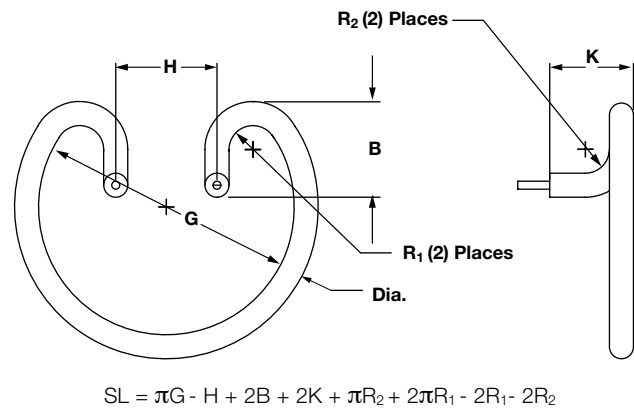

Figure 51

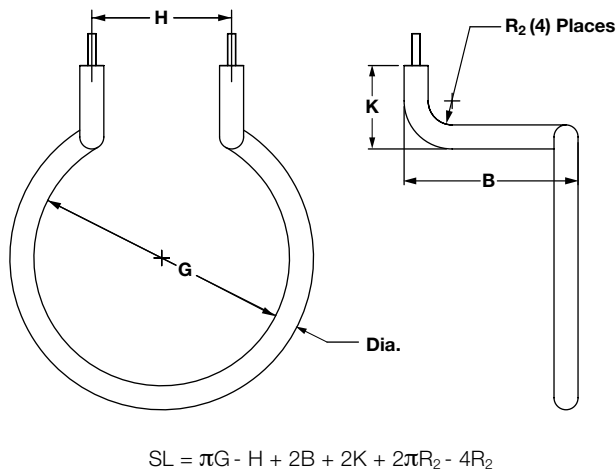
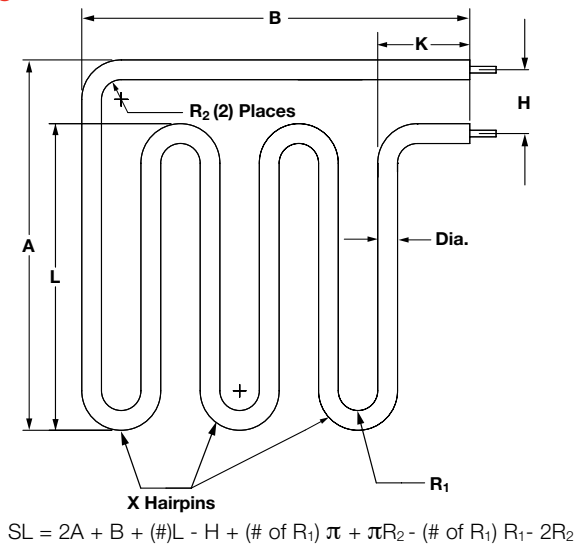

Figure 52



Tubular Heaters



WATROD Single/Double-Ended Heaters

Bend Formations (Continued)

Figure 53

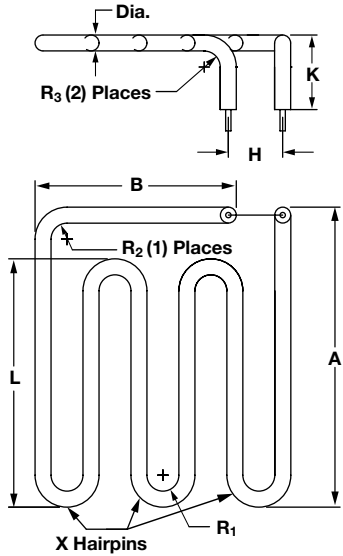

$$SL = 2A + (\#)L + B + 2K + (\# \text{ of } R_1) \pi + 2 \frac{(\pi R_3)}{2} - (\# \text{ of } R_1) R_1 - 2R_3 - R_2$$

Figure 54

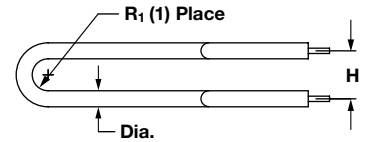
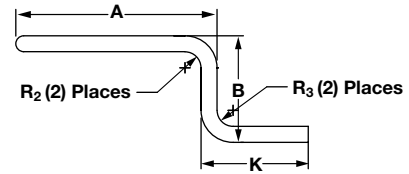

$$SL = 2A + 2B + 2K + \pi R_1 + 2\pi R_2 - R_1 - 4R_2$$

Figure 55

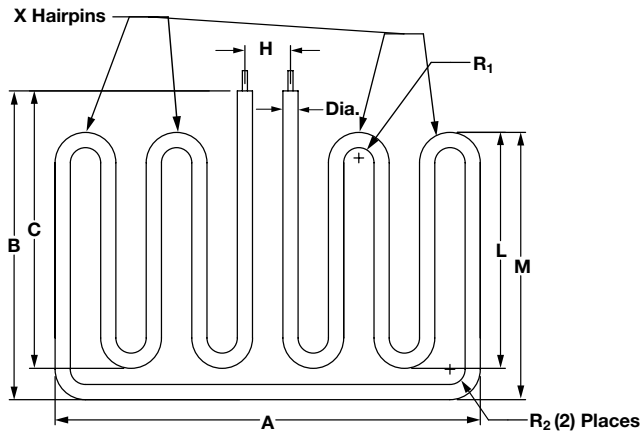

$$SL = A + 2C + 2M + (\#)L + (\# \text{ of } R_1) \pi + \pi R_2 - (\# \text{ of } R_1) R_1 - 2R_2$$

Figure 56

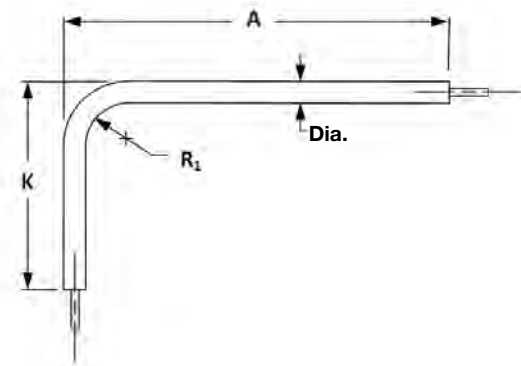

$$SL = A + K - 0.86R_1$$

Tubular Heaters



WATROD Single/Double-Ended Heaters

Mounting Methods

Brackets

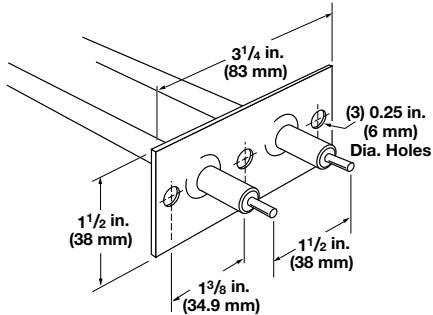

A 0.065 in. (1.7 mm) thick stainless steel bracket provides element mounting in non-pressurized applications. Attached to the heater sheath, these brackets are not suited for liquid-tight mountings. The bracket is located 1/2 in. (13 mm) from the sheath's end, unless otherwise specified.

To order, specify **mounting bracket**.

Single Leg Bracket

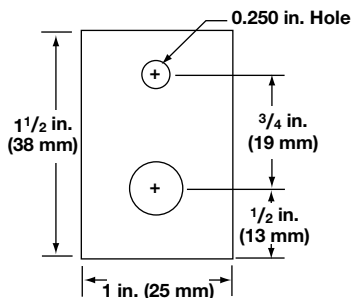

A 1 1/2 in. (38 mm) x 1 in. (25 mm) wide x 16 gauge stainless steel bracket with one element hole and one mounting hole 1/2 in. (13 mm) from end.

To order, specify **single leg bracket**.

Locator Washers

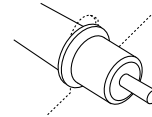

Stainless steel locator washers retain the heated area of the sheath in the work zone, while allowing for expansion and contraction during cycling.

To order, specify **locator washer**, along with dimension from the heater's end.

Tubular Heaters



WATROD Single/Double-Ended Heaters

Mounting Methods (Continued)

Threaded Bulkheads

A threaded bushing with flange on the heater sheath provides rigid, leak-proof mounting through the walls of tanks. A gasket, plated steel washer and hex nut are included. The threaded end of the bushing is flush with the sheath's end unless otherwise specified. Threaded bulkheads are available in brass, steel or stainless steel as indicated in the table.

To order, specify **threaded bulkheads** and the specifications from the table.

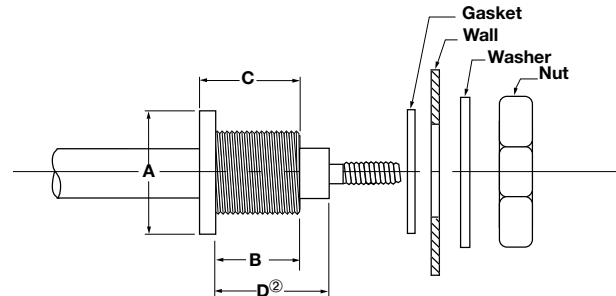

Threaded Bulkhead Specifications

Element Diameter		Material	Thread Size	A ① Flange Size/Style		B Threaded Length		C Overall Length	
in.	(mm)			in.	(mm)	in.	(mm)	in.	(mm)
0.260	(6.6)	Brass	1/2 - 20 UNF	3/4 Round	(19.0)	5/8	(15.9)	3/4	(19.0)
0.260	(6.6)	Steel ③	1/2 - 20 UNF	3/4 Hex	(19.0)	5/8	(15.9)	3/4	(19.0)
0.260	(6.6)	SS	1/2 - 20 UNF	3/4 Round	(19.0)	5/8	(15.9)	3/4	(19.0)
0.315	(8.0)	Brass	1/2 - 20 UNF	3/4 Round	(19.0)	5/8	(15.9)	3/4	(19.0)
0.315	(8.0)	Steel	1/2 - 20 UNF	3/4 Hex	(19.0)	3/4	(19.0)	15/16	(23.8)
0.315	(8.0)	SS	1/2 - 20 UNF	3/4 Round	(19.0)	3/4	(19.0)	27/32	(21.4)
0.375	(9.5)	Brass	1/2 - 20 UNF	3/4 Round	(19.0)	5/8	(15.9)	3/4	(19.0)
0.375	(9.5)	Steel	1/2 - 20 UNF	3/4 Hex	(19.0)	3/4	(19.0)	15/16	(23.8)
0.375	(9.5)	SS	1/2 - 20 UNF	3/4 Round	(19.0)	3/4	(19.0)	27/32	(21.4)
0.430	(10.9)	Brass	5/8 - 18 UNF	7/8 Hex	(22.2)	3/4	(19.0)	15/16	(23.8)
0.430	(10.9)	Steel	5/8 - 18 UNF	7/8 Round	(22.2)	3/4	(19.0)	15/16	(23.8)
0.430	(10.9)	SS	5/8 - 18 UNF	1 Round	(25.0)	3/4	(19.0)	15/16	(23.8)
0.475	(12.1)	Brass	5/8 - 18 UNF	7/8 Round	(22.2)	3/4	(19.0)	15/16	(23.8)
0.475	(12.1)	Steel	5/8 - 18 UNF	1 Round	(25.0)	1	(25.0)	1 1/8	(28.6)
0.475	(12.1)	SS	5/8 - 18 UNF	1 Round	(25.0)	3/4	(19.0)	15/16	(23.8)

① Designates the dimension across flats for hex flange style and outside diameter for round flange style.

② Equal to "B" dimension unless otherwise specified.

③ Extended capability only.

Tubular Heaters

WATROD Single/Double-Ended Heaters

**EXTENDED
CAPABILITY**



Extended Capabilities/Options

Zoned Heaters

Multiple zone heaters with up to (5) zones are available.

Features and Benefits

Standard sheath materials

- Optional materials available which include 304 SS, 316 SS, Alloy 600, Alloy 800, Alloy 840, copper clad steel, Inconel®/steel, and titanium

Extended Capabilities/Bend Formations

Figure 33

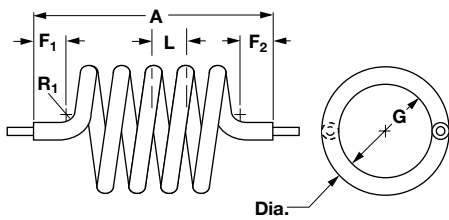

$$SL = [(G + \text{Dia.}) (3.14) (\text{Number of } 360^\circ\text{'s}) + F1 + F2]$$

Figure 34

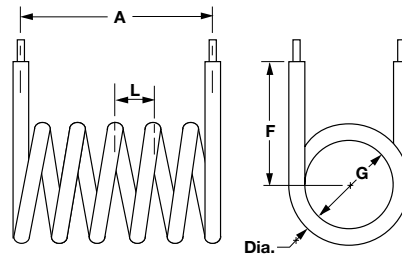

$$SL = [(G + \text{Dia.}) (3.14) (\text{Number of } 360^\circ\text{'s})] + 2F$$

Figure 35

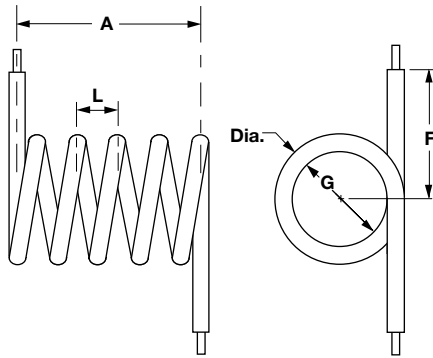

$$SL = [(G + \text{Dia.}) (3.14) (\text{Number of } 360^\circ\text{'s}) + 2F]$$

Figure 36

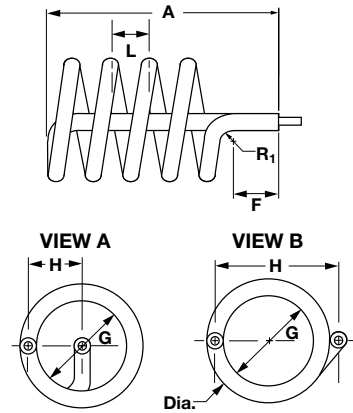

$$SL = [(G + \text{Dia.}) (3.14) (\text{Number of } 360^\circ\text{'s}) + (G \div 2) + A + F]$$

Tubular Heaters



WATROD Single/Double-Ended Heaters

Double-Ended WATROD

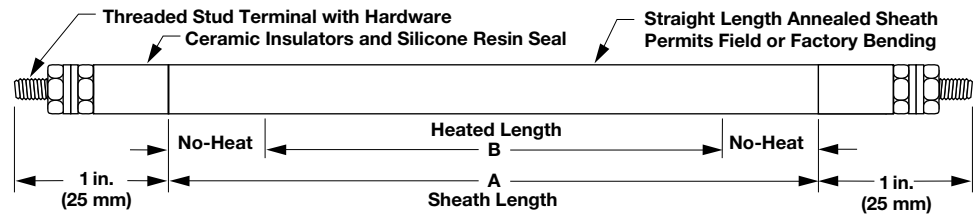

WATROD Description	Sheath A Dimension		Heated B Dimension		Watts	Part Number			Est. Net Wt.	
	in.	(mm)	in.	(mm)		120VAC	240VAC	480VAC	lbs	(kg)

Applications: Medium-Weight, Non-Circulating Oil, Heat-Transfer Oil

15 W/in² 0.475 in. Dia. Steel (2.3 W/cm²) (12 mm)	29 ⁷ / ₈	(758.8)	22 ³ / ₈	(568.4)	500	RGSS29R10S			1.0	(0.5)
	38 ³ / ₈	(974.7)	29 ⁷ / ₈	(758.8)	667	RGSS38G10S	RGSS38G11S		1.3	(0.6)
	44 ³ / ₄	(1137.0)	37 ¹ / ₄	(946.0)	833	RGSS44G10S	RGSS44G11S		1.7	(0.8)
	53 ³ / ₈	(1355.7)	44 ³ / ₄	(1137.0)	1000	RGSS53G10S	RGSS53G11S		1.9	(0.9)
	68 ³ / ₈	(1736.7)	59 ⁵ / ₈	(1514.4)	1333	RGSS68G10S	RGSS68G11S		2.1	(1.0)
	83 ³ / ₈	(2117.7)	74 ¹ / ₂	(1892.0)	1667	RGSS83G10S	RGSS83G11S		2.5	(1.1)
	98 ³ / ₈	(2498.7)	89 ¹ / ₂	(2273.0)	2000	RGSS98G10S	RGSS98G11S		3.0	(1.4)
	120 ³ / ₈	(3057.5)	111 ⁷ / ₈	(2841.6)	2500	RGSS120G10S	RGSS120G11S		3.9	(1.8)
142 ⁷ / ₈	(3629.1)	134 ¹ / ₄	(3410.0)	3000	RGSS142R10S	RGSS142R11S		4.1	(1.9)	

Application: Air Heating

20 W/in² 0.430 in. Dia. Alloy 840 (3.1 W/cm²) (10.9 mm)	48 ³ / ₄	(1238.0)	38 ³ / ₄	(984.0)	1000	RCN48N10S	RCN48N11S		1.0	(0.5)
	58 ³ / ₄	(1492.0)	48 ³ / ₄	(1238.0)	1250	RCN58N10S	RCN58N11S		1.1	(0.5)
	73 ³ / ₄	(1873.0)	63 ³ / ₄	(1619.0)	1667	RCN73N10S	RCN73N11S		1.4	(0.7)
	91 ³ / ₄	(2330.0)	81 ³ / ₄	(2076.0)	2083	RCN91N10S	RCN91N11S		1.7	(0.8)

Applications: Caustic Solutions, Air Heating

23 W/in² 0.315 in. Dia. Alloy 800 (3.6 W/cm²) (8 mm)	29	(737.0)	22	(559.0)	500	RBN291S			0.4	(0.2)	
	40	(1016.0)	33	(839.0)	750	RBN401S			0.5	(0.3)	
	51	(1296.0)	44	(1118.0)	1000	RBN511S			0.7	(0.4)	
23 W/in² 0.475 in. Dia. Alloy 800 (3.6 W/cm²) (12 mm)	39	(991.0)	27	(686.0)	1000	RGNA391S	RGNA3910S	RGNA3911S	1.2	(0.6)	
	54	(1372.0)	42	(1067.0)	1500		RGNA5410S	RGNA5411S	1.6	(0.8)	
	69	(1753.0)	57	(1448.0)	2000		RGNA6910S	RGNA6911S	2.1	(1.0)	
	84	(2134.0)	72	(1829.0)	2500		RGNA8410S	RGNA8411S	2.5	(1.2)	
	99	(2515.0)	87	(2210.0)	3000		RGNA9910S	RGNA9911S	3.0	(1.4)	
	106	(2692.0)	94	(2388.0)	2778			RGNA10611S		3.2	(1.5)
	132	(3353.0)	120	(3048.0)	4167			RGNA13211S		4.0	(1.8)
157	(3988.0)	145	(3683.0)	5000		RGNA15710S	RGNA15711S	4.7	(2.2)		

Applications: Light Oils, Greases, Heat-Transfer Oils

23 W/in² 0.315 in. Dia. Steel (3.6 W/cm²) (8 mm)	16	(406.0)	12	(305.0)	250	RBS161S	RBS1610S		0.2	(0.1)
	18	(457.0)	14	(356.0)	250	RBS181S			0.3	(0.2)
	21	(533.0)	17	(432.0)	350	RBS211S	RBS2110S		0.3	(0.2)
	23 ³ / ₈	(593.7)	19 ³ / ₈	(492.1)	375	RBS23G1S			0.3	(0.2)
	28 ⁷ / ₈	(733.4)	24 ⁷ / ₈	(631.8)	500	RBS28R1S			0.4	(0.2)
	29	(737.0)	24	(610.0)	500	RBS291S	RBS2910S		0.4	(0.2)
	42	(1067.0)	37	(940.0)	750	RBS421S	RBS4210S		0.6	(0.3)
	54	(1372.0)	49	(1245.0)	1000	RBS541S	RBS5410S		0.7	(0.4)
	77	(1956.0)	72	(1829.0)	1500	RBS771S	RBS7710S		1.0	(0.5)

CONTINUED

Tubular Heaters



WATROD Single/Double-Ended Heaters

Double-Ended WATROD (Continued)

WATROD Description	Sheath A Dimension		Heated B Dimension		Watts	Part Number			Est. Net Wt.	
	in.	(mm)	in.	(mm)		120VAC	240VAC	480VAC	lbs	(kg)

Applications: Light Oils, Greases, Heat-Transfer Oils

23 W/in² 0.475 in. Dia. Steel (3.6 W/cm²) (12 mm)	23	(584)	14	(356)	500	RGS231S	RGS2310S		0.7	(0.4)
	31	(787)	22	(559)	750	RGS311S	RGS3110S		1.0	(0.5)
	39	(991)	27	(686)	1000	RGS391S	RGS3910S	RGS3911S	1.2	(0.6)
	45	(1143)	36	(914)	1250	RGS451S	RGS4510S		1.4	(0.7)
	54	(1372)	42	(1067)	1500	RGS541S	RGS5410S	RGS5411S	1.6	(0.8)
	69	(1753)	57	(1448)	2000	RGS691S	RGS6910S	RGS6911S	2.1	(1.0)
	84	(2134)	72	(1829)	2500	RGS841S	RGS8410S	RGS8411S	2.5	(1.2)
	99	(2515)	87	(2210)	3000		RGS9910S	RGS9911S	3.0	(1.4)
	106	(2692)	90	(2286)	2778			RGS10611S	3.2	(1.5)
	132	(3353)	120	(3048)	4167		RGS13210S	RGS13211S	4.0	(1.8)
	144	(3658)	128	(3251)	3889			RGS14411S	4.3	(2.0)
	157	(3988)	145	(3683)	5000		RGS15710S	RGS15711S	4.7	(2.2)

Application: Air Heating

30 W/in² 0.260 in. Dia. Alloy 840 (4.7 W/cm²) (6.6 mm)	20	(508)	15	(381)	400		RAN2010S		0.2	(0.1)	
	25	(635)	20	(508)	500		RAN2510S		0.3	(0.2)	
	30	(762)	25	(635)	600		RAN3010S		0.3	(0.2)	
	35	(889)	30	(762)	800		RAN3510S		0.4	(0.2)	
	40	(1016)	35	(889)	900		RAN4010S		0.4	(0.2)	
	45	(1143)	40	(1016)	1000		RAN4510S		0.5	(0.3)	
	50	(1270)	45	(1143)	1200		RAN5010S		0.5	(0.3)	
	55	(1397)	50	(1270)	1200		RAN5510S		0.6	(0.3)	
	60	(1524)	55	(1397)	1400		RAN6010S		0.6	(0.3)	
	65	(1651)	60	(1524)	1600		RAN6510S		0.7	(0.4)	
	70	(1778)	65	(1651)	1800		RAN7010S		0.7	(0.4)	
	75	(1905)	70	(1778)	1800		RAN7510S		0.8	(0.4)	
	80	(2032)	75	(1905)	2000		RAN8010S		0.8	(0.4)	
	30 W/in² 0.315 in. Dia. Alloy 840 (4.7 W/cm²) (8 mm)	15	(381)	10	(254)	300		RBN1510S		0.2	(0.1)
		20	(508)	15	(381)	400		RBN2010S		0.3	(0.2)
25		(635)	20	(508)	600		RBN2510S		0.4	(0.2)	
30		(762)	25	(635)	800		RBN3010S		0.4	(0.2)	
35		(889)	30	(762)	900		RBN3510S		0.5	(0.3)	
40		(1016)	35	(889)	1000		RBN4010S		0.5	(0.3)	
45		(1143)	40	(1016)	1200		RBN4510S		0.6	(0.3)	
50		(1270)	45	(1143)	1400		RBN5010S		0.7	(0.4)	
55		(1397)	50	(1270)	1600		RBN5510S		0.7	(0.4)	
60		(1524)	55	(1397)	1800		RBN6010S		0.8	(0.4)	
65		(1651)	60	(1524)	1800		RBN6510S		0.8	(0.4)	
70		(1778)	65	(1651)	2000		RBN7010S		0.9	(0.5)	
75		(1905)	70	(1778)	2200		RBN7510S		1.0	(0.5)	
80		(2032)	75	(1905)	2400		RBN8010S		1.0	(0.5)	
90		(2286)	85	(2159)	2600		RBN9010S		1.2	(0.6)	
100	(2540)	95	(2413)	3000		RBN10010S		1.3	(0.6)		

CONTINUED

Tubular Heaters



WATROD Single/Double-Ended Heaters

Double-Ended WATROD (Continued)

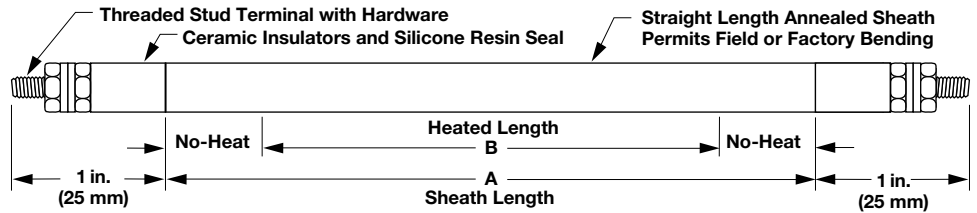

WATROD Description	Sheath A Dimension		Heated B Dimension		Watts	Part Number			Est. Net Wt.	
	in.	(mm)	in.	(mm)		120VAC	240VAC	480VAC	lbs	(kg)

Application: Air Heating

30 W/in² 0.430 in. Dia. Alloy 840 (4.7 W/cm²) (10.9 mm)	15	(381.0)	10	(254.0)	400	RCN1510S			0.3	(0.2)
	20	(508.0)	15	(381.0)	600	RCN2010S			0.4	(0.2)
	25	(635.0)	20	(508.0)	800	RCN2510S			0.5	(0.3)
	30	(762.0)	25	(635.0)	1000	RCN3010S			0.6	(0.3)
	35	(889.0)	30	(762.0)	1200	RCN3510S			0.7	(0.4)
	40	(1016.0)	35	(889.0)	1400	RCN4010S			0.8	(0.4)
	48 ^{3/4}	(1238.0)	38 ^{3/4}	(984.0)	1500	RCNX48N10S	RCNX48N11S		1.0	(0.5)
	45	(1143.0)	40	(1016.0)	1600	RCN4510S			0.9	(0.5)
	50	(1270.0)	45	(1143.0)	1800	RCN5010S			1.0	(0.5)
	58 ^{3/4}	(1492.0)	48 ^{3/4}	(1238.0)	1917	RCNX58N10S	RCNX58N11S		1.1	(0.5)
	55	(1397.0)	50	(1270.0)	2000	RCN5510S			1.0	(0.5)
	60	(1524.0)	55	(1397.0)	2200	RCN6010S			1.1	(0.5)
	65	(1651.0)	60	(1524.0)	2400	RCN6510S			1.2	(0.6)
	73 ^{3/4}	(1873.0)	63 ^{3/4}	(1619.0)	2500		RCNX73N11S		1.4	(0.7)
	70	(1778.0)	65	(1651.0)	2600	RCN7010S			1.3	(0.6)
	75	(1905.0)	70	(1778.0)	2800	RCN7510S			1.4	(0.7)
	80	(2032.0)	75	(1905.0)	3000	RCN8010S			1.5	(0.7)
	91 ^{3/4}	(2331.0)	81 ^{3/4}	(2077.0)	3167		RCNX91N11S		1.7	(0.8)
90	(2286.0)	85	(2159.0)	3500	RCN9010S			1.7	(0.8)	
100	(2540.0)	95	(2413.0)	4000	RCN10010S			1.9	(0.9)	
110	(2794.0)	105	(2667.0)	4500	RCN11010S			2.1	(1.0)	
120	(3048.0)	115	(2921.0)	5000	RCN12010S			2.3	(1.1)	

Application: Radiant Heating

40 W/in² 0.375 in. Dia. Alloy 800 (6.2 W/cm²) (9.5 mm)	10 ^{1/4}	(260.0)	7 ^{1/4}	(184.0)	400	RDN10E1S			0.2	(0.1)
	16 ^{5/8}	(422.1)	13 ^{5/8}	(346.1)	650	RDN16L1S			0.3	(0.2)
	21 ^{1/16}	(535.0)	16 ^{13/16}	(427.0)	800	RDN21B1S	RDN21B10S		0.4	(0.2)
	27 ^{1/8}	(689.0)	22 ^{7/8}	(581.0)	1100	RDN27C1S	RDN27C10S		0.5	(0.3)
	32 ^{1/8}	(816.0)	27 ^{7/8}	(708.0)	1300		RDN32C10S	RDN32C11S	0.6	(0.3)
	42 ^{7/8}	(1089.0)	38 ^{5/8}	(981.1)	1800		RDN42R10S	RDN42R11S	0.8	(0.4)
	57 ^{1/2}	(1461.0)	53 ^{1/4}	(1353.0)	2500		RDN57J10S	RDN57J11S	1.1	(0.5)
	69 ^{1/4}	(1759.0)	65	(1651.0)	3000		RDN69E10S	RDN69E11S	1.3	(0.6)
	81 ^{1/4}	(2064.0)	77	(1956.0)	3600		RDN81E10S	RDN81E11S	1.6	(0.8)
	109 ^{1/4}	(2775.0)	105	(2667.0)	4000		RDN109E10S		2.1	(1.0)
	134 ^{1/2}	(3416.0)	127 ^{3/4}	(3245.0)	5000		RDN134J10S		2.6	(1.2)
	153 ^{3/8}	(3895.7)	145 ^{7/8}	(3705.2)	5500		RDN153R10S		2.9	(1.4)
	179 ^{1/4}	(4553.0)	171 ^{1/4}	(4350.0)	6500		RDN179E10S		3.4	(1.6)

CONTINUED

Tubular Heaters



WATROD Single/Double-Ended Heaters

Double-Ended WATROD (Continued)

Special 208VAC and 277VAC Voltages

WATROD Description	Sheath A Dimension		Heated B Dimension		Watts	Part Number		Est. Net Wt.	
	in.	(mm)	in.	(mm)		208VAC	277VAC	lbs	(kg)

Application: Radiant Heating

40 W/in ² 0.375 in. Dia. Alloy 800	21 ¹ / ₁₆	(535)	16 ¹³ / ₁₆	(427)	800	RDN21B2S	RDN21B4S	0.4	(0.2)
	27 ¹ / ₈	(689)	22 ⁷ / ₈	(581)	1100	RDN27C2S	RDN27C4S	0.5	(0.3)
	42 ⁷ / ₈	(1089)	38 ⁵ / ₈	(981)	1800	RDN42R2S	RDN42R4S	0.8	(0.4)
(6.2 W/cm ²) (9.5 mm)	57 ¹ / ₂	(1461)	53 ¹ / ₄	(1353)	2500	RDN57J2S	RDN57J4S	1.1	(0.5)
	69 ¹ / ₄	(1759)	65	(1651)	3000	RDN69E2S	RDN69E4S	1.3	(0.6)
	81 ¹ / ₄	(2064)	77	(1956)	3600	RDN81E2S	RDN81E4S	1.6	(0.8)

WATROD Description	Sheath A Dimension		Heated B Dimension		Watts	Part Number			Est. Net Wt.	
	in.	(mm)	in.	(mm)		120VAC	240VAC	480VAC	lbs	(kg)

Application: Process Water

48 W/in ² 0.475 in. Dia. Alloy 800 (7.4 W/cm ²) (12 mm)	23	(584)	14	(356)	1000	RGN231S	RGN2310S	RGN2311S	0.7	(0.4)
	30	(762)	21	(533)	1500	RGN301S	RGN3010S	RGN3011S	0.9	(0.5)
	39	(991)	27	(686)	2000	RGN391S	RGN3910S	RGN3911S	1.2	(0.6)
	44	(1118)	35	(889)	2500	RGN441S	RGN4410S	RGN4411S	1.3	(0.6)
	54	(1372)	42	(1067)	3000		RGN5410S	RGN5411S	1.6	(0.8)
	69	(1753)	57	(1448)	4000		RGN6910S	RGN6911S	2.1	(1.0)
	84	(2134)	72	(1829)	5000		RGN8410S	RGN8411S	2.5	(1.2)
	92	(2337)	76	(1930)	5556			RGN9211S	2.8	(1.3)
	99	(2515)	87	(2210)	6000		RGN9910S	RGN9911S	3.0	(1.4)
	149	(3785)	133	(3378)	9722			RGN14911S	4.5	(2.1)

Application: Hot Runner Molds (Manifolds)

60 W/in ² 0.315 in. Dia. 316 SS (9.3 W/cm ²) (8 mm)	35	(889)	25	(635)	1500		RBR3510S		0.2	(0.1)
	44	(1118)	34	(864)	2000		RBR4410S		0.3	(0.2)
	52	(1321)	42	(1067)	2500		RBR5210S		0.3	(0.2)
	60	(1524)	50	(1270)	3000		RBR6010S		0.4	(0.2)
	69	(1753)	59	(1499)	3500		RBR6910S		0.4	(0.2)
	77	(1956)	67	(1702)	4000		RBR7710S		0.5	(0.3)
	85	(2159)	75	(1905)	4500		RBR8510S		0.6	(0.3)

Applications: Deionized Water, Demineralized Water

60 W/in ² 0.475 in. Dia. 316 SS (9.3 W/cm ²) (12 mm)	20	(508)	11	(279)	1000	RGR201S	RGR2010S	RGR2011S	0.6	(0.3)
	26	(660)	17	(432)	1500	RGR261S	RGR2610S	RGR2611S	0.8	(0.4)
	34	(864)	22	(559)	2000		RGR3410S	RGR3411S	1.0	(0.5)
	40	(1016)	28	(711)	2500		RGR4010S	RGR4011S	1.2	(0.6)
	47	(1194)	31	(787)	2778			RGR4711S	1.4	(0.7)
	46	(1168)	34	(864)	3000		RGR4610S	RGR4611S	1.4	(0.7)
	57	(1448)	45	(1143)	4000		RGR5710S	RGR5711S	1.7	(0.8)
	68	(1727)	56	(1422)	5000		RGR6810S	RGR6811S	2.1	(1.0)
	79	(2007)	67	(1702)	6000		RGR7910S	RGR7911S	2.4	(1.1)
	105	(2667)	93	(2362)	8333			RGR10511S	3.2	(1.5)

Tubular Heaters



WATROD Single/Double-Ended Heaters

Single-Ended WATROD

Application Hints

The single-ended WATROD heater's construction limits its usefulness in some applications. The following are some guides to follow when considering a single-ended WATROD.

- When single-ended termination simplifies application wiring.
- The application requires lower wattage or a smaller package.
- Do not locate the end of the heated length within a bend, unless the radius is 3 in. (75 mm) or more. Field bending is not recommended.
- Bending is limited to bend Figures 1, 6, 22 and 28 (see pages 62 to 67 for details).
- Ensure termination temperatures do not exceed 390°F (200°C) or the seal's maximum rating.
- Keep terminations clean, dry and tight.

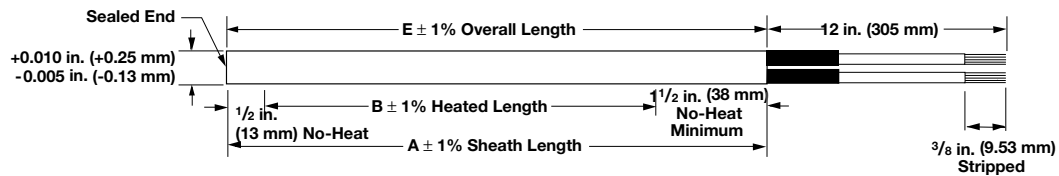

Tubular Heaters

**EXTENDED
CAPABILITY**



WATROD Double-Ended Heaters

Extended Capabilities for High-Temperature Tubular Heaters

Watlow manufactures high-temperature tubular heaters to bridge the gap between standard tubular heaters and Watlow MULTICELL™ heaters. This tubular is well suited for process air heating applications in excess of 1300°F (704°C), resulting in a maximum sheath temperature of 1800°F (983°C). Controlled lab testing between the new design and current tubular designs show an increase in life of approximately 50 percent.

The high-temperature tubular consists of an engineered tubing with an alloy 600 outer sheath and a special internal construction. The outer sheath offers high temperature capabilities, reduced oxidation as well as corrosion resistance.

The tubular offering is available in 0.430 and 0.375 inch diameters that are configurable either as formed tubulars or process heaters. The heaters can also be welded to flanges and plates for mounting purposes. Maximum sheath length available is 275 inches for the 0.430 inch and 0.375 inch diameters. A Watlow sales representative should be contacted for longer sheath lengths.

Features and Benefits

Alloy 600 sheath material and a special internal construction

- Assures high temperature performance and corrosion protection in tough applications

0.430 inch diameters*

- Allows heater to be configured to existing tubular designs that may be experiencing short life

***Note: 0.375 diameters are available in Watlow's extended capabilities, contact your Watlow representative for details.**

Dual-ended termination

- Installs into flanges and screw plugs similarly to standard product configurations

Bendable in standard formations

- Makes the heater easy to apply in a wide variety of applications

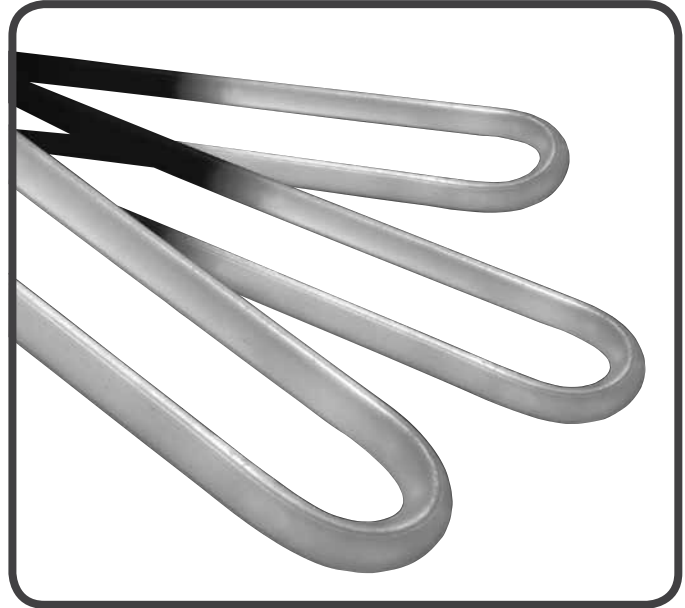

Typical Applications

- High temperature ovens and furnaces
- Radiant heating
- Drying
- Environmental—VOC abatement
- Process air heating: duct heaters, circulation heaters
- Vacuum applications
- Flue gas cleaning (desulphurization)
- Fluidized beds

Tubular Heaters

**EXTENDED
CAPABILITY**



WATROD Double-Ended Heaters

Extended Capabilities for High-Temperature Tubular Heaters

Sheath Temperature Versus Oven Temperature at Various Watt Densities

This chart is used to verify the correct watt density for an oven application assuming no air flow. To use the chart, first select the oven process temperature on the X axis, using the chosen watt density read the sheath temperature rise above oven temperature from the Y axis. This number should then be added to oven temperature. If this number is greater than 1800°F (982°C), a lower watt density should be chosen.

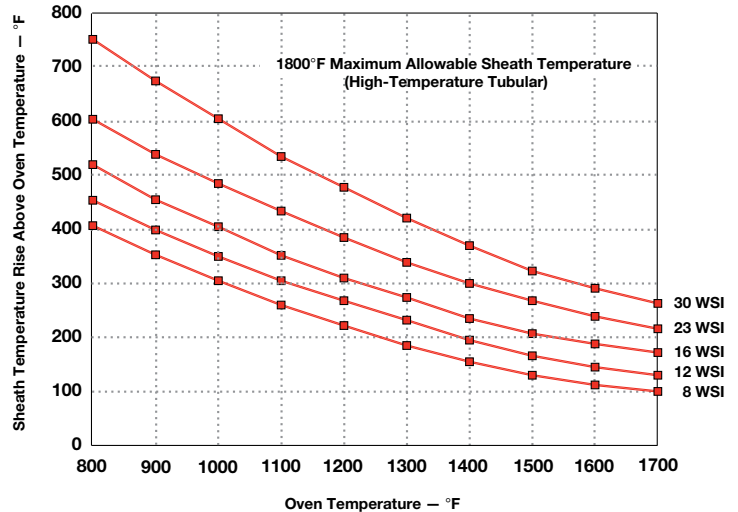

Heater Life Estimate Service

Watlow now provides an industry first service with the offering of the high-temperature tubular. By providing operating parameters, Watlow provides customers with the estimated life of the heater. To get this information, the following information should be provided:

- Heater voltage
- Heater wattage
- Heater diameter 0.430 or 0.375 in. (10.9 or 9.5 mm)
- Heated length
- Bend configuration and dimensions (number of bends and radius)
- Application including process temperature
- Power switching device and cycle time (SCR, etc.)

High-Temperature Heater Comparisons

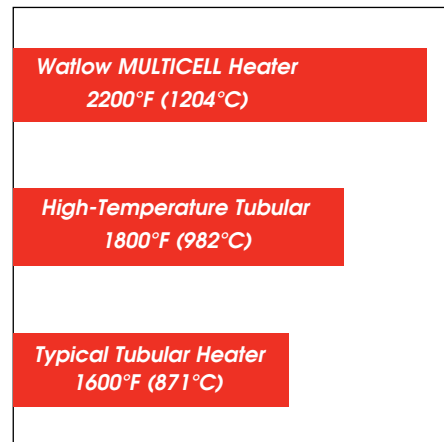

*Assuming normal design practices.

Tubular Heaters

**EXTENDED
CAPABILITY**



WATROD Single/Double-Ended Heaters

Extended Capabilities for MULTICOIL™ Tubular Heaters

The tubular element with multiple coils and/or thermocouples inside one sheath from Watlow answers the need for a versatile, innovative tubular heater. Watlow's patented method of packaging a thermocouple inside of a heater with one or more resistance coils, gives the ability to sense a heaters' internal temperature accurately, every time.

Moreover, this is the first tubular heater in the industry with three-phase capability. The three coil, three-phase heater will offer a compact package solution while delivering the full power required in a compact heater package. Previously three separate heaters would have been required to do the same job; therefore Watlow's MULTICOIL™ heater capabilities save money.

Performance Capabilities

- Watt densities up to 60 W/in² (9.3 W/cm²)
- Sheath temperatures up to 1600°F (870°C)
- 304 and 316 stainless steel sheath temperatures up to 1200°F (650°C)

Features and Benefits

Three-phase capability

- Results in one element versus three, lower amperage, reduced installation time and lower overall cost

Multiple coil operations

- Reduces inventory by allowing dual voltage capability

Versatile forming capabilities

- Forms into many configurations

Internal construction with sensor

- Allows space savings because drilling and tapping of flange is unnecessary; plus, the interior thermocouple eliminates contamination buildup around the external sensing tip, reducing the possibility of false readings

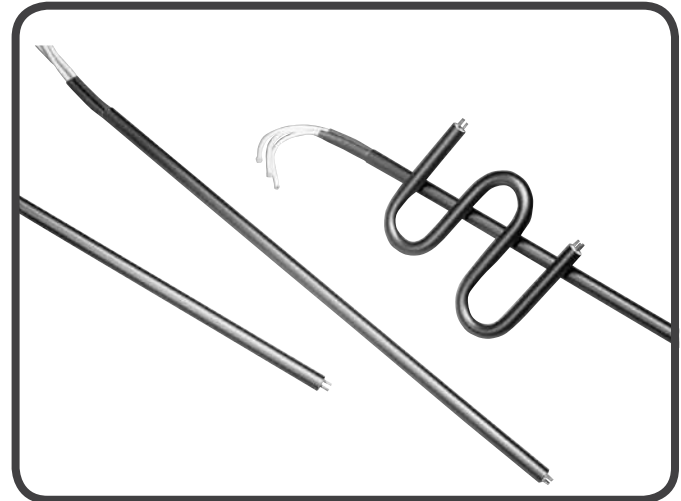

Typical Applications

- Foodservice equipment
- Process
- Medical
- Milled groove
- Plastics
- Plating
- Oven heating
- Semiconductor

Tubular Heaters

**EXTENDED
CAPABILITY**



WATROD Single/Double-Ended Heaters

Extended Capabilities for MULTICOIL Tubular Heaters

Options

Option A

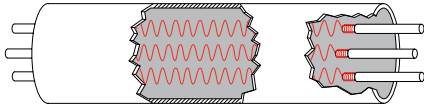

3-phase tubular, 0.475 inch diameter.

Option E

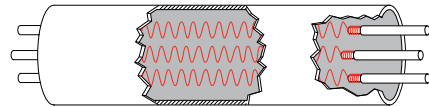

1-phase tubular with three different one phase circuits, 0.475 inch diameter.

Option C

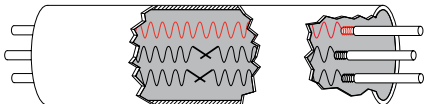

1-phase tubular with one resistance wire and two thermocouples, 0.475 inch diameter.

Option F

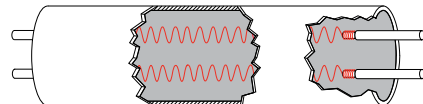

1-phase tubular with two resistance coils, 0.375, 0.430 and 0.475 inch diameter.

Option D

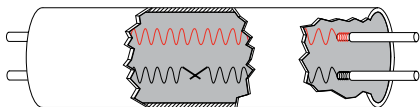

1-phase tubular with one resistance coil and one thermocouple, 0.375, 0.430 and 0.475 inch diameter.

Specifications

Termination styles

- Lead wires 392°F (200°C)
Sil-A-Blend® or 482°F (250°C) GGS.

Moisture seals

Moisture seals are required, options include:

- Epoxy with temperature rating to 356°F (180°C).
Typical applications include water/oil immersion.
- Lavacone with temperature rating to 221°F (105°C).
Typical application includes air heating.
- High-temperature ceramic rated to 2800°F (1538°C).
- Contact your Watlow representative for other moisture seal options.

Mounting options

- Mounting brackets
- Locator washers
- Water-tight bulkheads

Maximum trim length

- 237 in. (6020 mm), heater designs with trim length greater than 120 in. (3048 mm) must be reviewed with your Watlow representative.

Sheath materials

- Alloy 600, 800, 840, 304 and 316 stainless steel, contact your Watlow representative for other sheath material options.

Internal thermocouple options

- Type K is used, contact your Watlow representative for Type J thermocouple options.

Tubular Heaters



FIREBAR® Single/Double-Ended Heaters

FIREBAR® heating elements provide added heating performance over standard round tubular heating elements—especially for immersion applications in petroleum based liquids requiring high kilowatts.

The FIREBAR's unique flat surface geometry packs more power in shorter elements and assemblies, along with a host of other performance improvements. These include:

- Minimizing coking and fluid degrading
- Enhancing the flow of fluid past the element's surface to carry heat from the sheath
- Improving heat transfer with a significantly larger boundary layer allowing much more liquid to flow up and across the sheath's surface

FIREBAR elements are available in single- and double-ended constructions with one inch or $\frac{5}{8}$ inch heights. These two configuration variables make it possible to use FIREBAR elements instead of round tubular elements in virtually all applications.

FINBAR™ is a special version of the one inch, single-ended FIREBAR. FINBAR is specially modified with fins to further increase surface area for air and gas heating applications. Details are contained in the *FINBAR* section, starting on page 103.

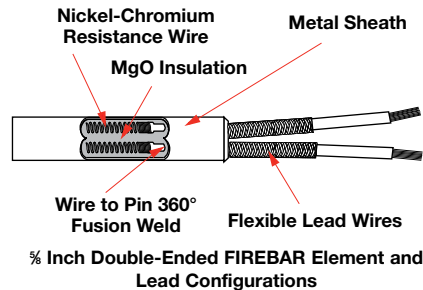
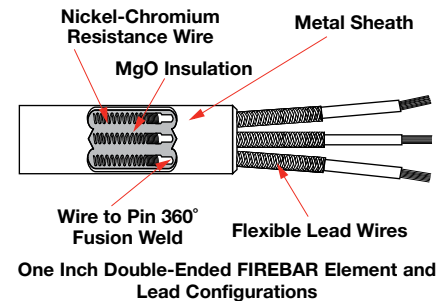
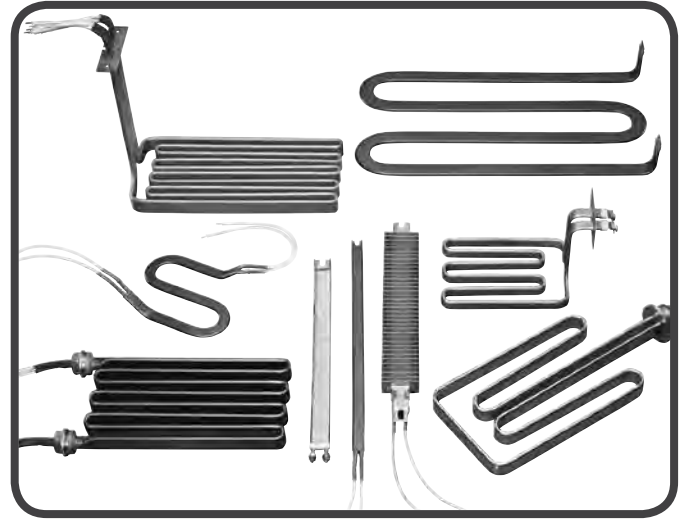

Double-Ended Performance Capabilities

One Inch

- Watt densities up to 120 W/in² (18.6 W/cm²)
- Alloy 800 sheath temperatures up to 1400°F (760°C)
- 304 stainless steel sheath temperatures up to 1200°F (650°C)
- Voltages up to 240VAC
- Amperages up to 48 amperes per heater or 16 amperes per coil

$\frac{5}{8}$ Inch

- Watt densities up to 90 W/in² (13.9 W/cm²)
- Alloy 840 sheath temperatures up to 1400°F (760°C)
- Voltages up to 240VAC
- Amperages up to 32 amperes per heater or 16 amperes per coil

Single-Ended Performance Capabilities

One Inch

- Watt densities up to 60 W/in² (9.3 W/cm²)
- Alloy 800 sheath temperatures up to 1400°F (760°C)
- 304 stainless steel sheath temperatures up to 1200°F (650°C)
- Voltages up to 240VAC
- Amperages up to 48 amperes per heater or 16 amperes per coil

$\frac{5}{8}$ Inch

- Watt densities up to 80 W/in² (12.4 W/cm²)
- Alloy 840 sheath temperatures up to 1400°F (760°C)
- Voltages up to 240VAC
- Amperages up to 16 amperes per heater

Tubular Heaters



FIREBAR Double-Ended Heaters

Specifications

One Inch FIREBAR



5/8 Inch FIREBAR



Applications	Direct immersion; water, oils, etc. Clamp-on; hoppers, griddles Forced air heating (Also see FINBAR, page 103) Radiant heating	Direct immersion; water, oils, etc. Clamp-on; hoppers, griddles Forced air heating Radiant heating
Watt Density W/in ² (W/cm ²)	Standard: up to 90 (13.9) Made-to-Order (M-t-O): up to 120 (18.6)	Standard: up to 90 (13.9) Made-to-Order (M-t-O): up to 90 (13.9)
Surface Area Per Linear In. (cm)	2.3 in ² (14.8 cm ²)	1.52 in ² (9.80 cm ²)
Cross Section Height ± 0.015/0.010 in. (0.381/0.254 mm) Thickness ± 0.005/0.001 in. (0.127/0.025 mm)	1.010 (25.7) 0.235 (5.9)	0.650 (16.5) 0.235 (5.9)
Sheath Material—Max. Operating temperature	Standard: Alloy 800 1400°F (760°C) M-t-O: Alloy 800 1400°F (760°C) 304 SS 1200°F (650°C)	Standard: Alloy 840 1400°F (760°C) M-t-O: Alloy 840 1400°F (760°C) 304 SS 1200°F (650°C)
Sheath Length in. (mm)	Standard: 15 to 114 (381 to 2896) M-t-O: 11 to 180 (280 to 4572)	Standard: 15 to 51 (381 to 1295) M-t-O: 11 to 115 (280 to 2920)
Straightness Tolerance Major axis in./ft (cm/m): Minor axis in./ft (cm/m):	0.062 (0.52) 0.062 (0.52)	0.062 (0.52) 0.062 (0.52)
No-Heat Length	1 in. min., 12 in. max. (25/305 mm)	1 in. min., 12 in. max. (25/305 mm)
Max. Voltage—Amperage Max. Hipotential Max. Current Leakage Per Coil (cold) Max. Amperage Per Coil Phase(s) Resistance Coils	240VAC—48A 1480VAC 3mA 16A 1-ph parallel/series, 3-ph delta/wye 3 or 2	240VAC—32A 1480VAC 3mA 16A 1-ph parallel/series 2
Ohms/In./Unit ^① Ohms/In./Coil ^①	0.270Ω min.—2.833Ω max. 0.080Ω min.—8.500Ω max. per coil	0.040Ω min.—4.250Ω max. 0.080Ω min.—8.500Ω max. per coil
Terminations	Flexible lead wires Quick connect (spade) Screw lug (plate) Threaded stud	Flexible lead wires Quick connect (spade) Screw lug (plate) Threaded stud
Seals	Standard: Lavacone 221°F (105°C) M-t-O: Ceramic base 2800°F (1535°C) Silicone rubber 392°F (200°C) Lavacone 221°F (105°C) Epoxy resin 266/356°F (130/180°C)	Standard: Lavacone 221°F (105°C) M-t-O: Ceramic base 2800°F (1535°C) Silicone rubber 392°F (200°C) Lavacone 221°F (105°C) Epoxy resin 266/356°F (130/180°C)
Min. Axis Bending Radius in. (mm) (Do not field bend)	Major: 1 (25) Minor: ½ (13) 90° bend Minor: ¼ (4) 180° bend	Major: ¾ (19) Minor: ½ (13) 90° bend Minor: ¼ (4) 180° bend
Mounting Options	Brackets (Type 1, 2 and 3) Threaded bulkhead or fitting	Brackets (Type 1, 2 and 3) Threaded bulkhead or fitting
Surface Finish Options	Bright anneal, passivation	Bright anneal, passivation
Agency Recognition	UL® component recognition to 240VAC (File # E52951) CSA component recognition to 240VAC (File # 31388)	UL® component recognition to 240VAC (File # E52951) CSA component recognition to 240VAC (File # 31388)

① Resistance values valid for three coil 1 in. (25 mm) FIREBAR only.

Tubular Heaters



FIREBAR Single-Ended Heaters

Specifications (Continued)

One Inch Single-Ended FIREBAR

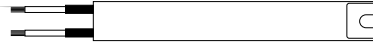

5/8 Inch Single-Ended FIREBAR

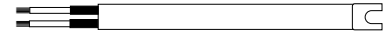

Applications	Clamp-on; hoppers, griddles Forced or convection air heating (Also see FINBAR, page 103)	Clamp-on; hoppers, griddles Forced or convection air heating
Watt Density W/in ² (W/cm ²)	Standard: up to 40 (6.2) M-t-O: up to 60 (9.3)	Standard: up to 20 (3.1) M-t-O: up to 60 (12.4)
Surface Area Per Linear In. (cm)	2.3 in ² (14.8 cm ²)	1.52 in ² (9.80 cm ²)
Cross Section Height ± 0.015/0.010 in. (0.381/0.254 mm) Thickness ± 0.005/0.001 in. (0.127/0.025 mm)	1.010 (25.7) 0.235 (5.9)	0.650 (16.5) 0.235 (5.9)
Sheath Material—Max. Operating temperature	Standard: 304 SS 1200°F (650°C) M-t-O: Alloy 800 1400°F (760°C) 304 SS 1200°F (650°C)	Standard: Alloy 840 1400°F (760°C) M-t-O: Alloy 840 1400°F (760°C) 304 SS 1200°F (650°C)
Sheath Length in. (mm)	Standard: 11 to 46¼ (280 to 1175) M-t-O: 11 to 120 (280 to 3048)	Standard: 11½ to 52 (280 to 1321) M-t-O: 11 to 116 (280 to 2946)
Straightness Tolerance Major axis in./foot (cm/m): Minor axis in./foot (cm/m):	0.062 (0.52) 0.062 (0.52)	0.062 (0.52) 0.062 (0.52)
No-Heat Length Top cold end Bottom (blunt end) cold end	1 in. min., 12 in. max. (25/305 mm) 1 ph- 0.5 min., 2 in. max. (13/51 mm) 3 ph- 0.75 min., 2 in. max. (19/51 mm)	1 in. min., 12 in. max. (25/305 mm) Only available at 1.25 in. N/A
Max. Voltage—Amperage Max. Hipotential Max. Current Leakage (cold) Max. Amperage Per Coil Phase(s) Resistance Coils	240VAC—48A 1480VAC 3mA 16A 1-ph, 3-ph wye 3 or 1	240VAC—16A 1480VAC 3mA 16A 1-ph 1
Ohms/In./Unit	0.200Ω min. — 14.00Ω max. ①	0.200Ω min. — 14.00Ω max. ①
Terminations	Flexible lead wires Threaded stud Quick connect (spade) Screw lug (plate)	Flexible lead wires Quick connect (spade) Screw lug (plate)
Seals	Standard: Lavacone 221°F (105°C) M-t-O: Ceramic base 2800°F (1535°C) Silicone rubber 392°F (200°C) Lavacone 221°F (105°C) Epoxy resin 266/356°F (130/180°C)	Standard: Lavacone 221°F (105°C) M-t-O: Ceramic base 2800°F (1535°C) Silicone rubber 392°F (200°C) Lavacone 221°F (105°C) Epoxy resin 266/356°F (130/180°C)
Min. Axis Bending Radius in. (mm) (Do not field bend)	Major: 1 (25) Minor: ½ (13) 90° bend Minor: ¼ (4) 180° bend	Major: ¾ (19) Minor: ½ (13) 90° bend Minor: ¼ (4) 180° bend
Mounting Options	Bracket (Type 2) Threaded bulkhead	Bracket (Type 2) Threaded bulkhead
Surface Finish Options	Bright anneal	Bright anneal
Optional Internal Thermocouple	—	—
Single-end Configuration	Standard: Slotted M-t-O: Slotted, sealed or welded	Standard: Slotted M-t-O: Slotted, sealed or welded
Agency Recognition	UL® component recognition to 240VAC (File # E52951) CSA component recognition to 240VAC (File # 31388)	UL® component recognition to 240VAC (File # E52951) CSA component recognition to 240VAC (File # 31388)

① Based on 1-phase, single voltage heater.



FIREBAR Single/Double-Ended Heaters

Features and Benefits

One Inch Features and Benefits

Double-Ended

Streamline, 0.235 x 1.010 in. (5.9 x 25.6 mm) normal to flow dimension

- Reduces drag

70 percent greater surface area per linear inch compared to a 0.430 in. (11 mm) diameter round tubular heater

- Reduces watt density or packs more kilowatts in smaller bundles

Compacted MgO insulation

- Maximizes thermal conductivity and dielectric strength

Nickel-chromium resistance wires

- Precision wound

0.040 in. (1 mm) thick MgO walls

- Transfers heat more efficiently away from the resistance wire to the sheath and media—conducts heat out of the element faster

Three resistance coil design

- Configurable to either one- or three-phase power, readily adapts to a variety of electrical sources and wattage outputs

Lavacone seals

- Provides protection against humid storage conditions, moisture retardant to 221°F (105°C)

Single-Ended

Single-ended termination

- Simplifies wiring and installation

Streamline, 0.235 x 1.010 in. (5.9 x 25.6 mm) normal to flow dimension

- Reduces drag

70 percent greater surface area per linear inch

- Reduces watt density from that of the 0.430 in. (11 mm) diameter round tubular

Slotted end

- Provides installation ease in clamp-on applications

Lavacone seals

- Provides protection against humid storage conditions, moisture retardant to 221°F (105°C)

5/8 inch Features and Benefits

Double-Ended

Special sheath dimensions, 0.235 x 0.650 in. (5.9 x 16.5 mm)

- Results in a lower profile heater

10 percent greater surface area per linear inch

- Reduces watt density from that of the 0.430 in. (11 mm) diameter round tubular heater

0.040 in. (1 mm) thick MgO walls

- Transfers heat efficiently away from the resistance wire to the heated media—conducts heat out of the element faster

Lavacone seals

- Provides protection against humid storage conditions, moisture retardant to 221°F (105°C)

Single-Ended

Single-ended termination

- Simplifies wiring and installation

Special sheath dimensions, 0.235 x 0.650 in. (5.9 x 16.5 mm)

- Results in a lower profile heater for more wattage in a smaller package

Slotted end

- Provides installation ease in clamp-on applications

Lavacone seals

- Provides protection against humid storage conditions, moisture retardant to 221°F (105°C)



FIREBAR Single/Double-Ended Heaters

Performance Features

FIREBAR's flat tubular element geometry produces performance features and benefits not possible with traditional round tubular technology. The following describes how and why the FIREBAR is functionally superior for many applications—especially those requiring large wattage with low watt density.

By using the FIREBAR element it will:

- Lower the element's watt density
- Reduce element size and keep the same watt density
- Increase element life by reducing sheath temperature

Flat Shape Produces Lower Sheath Temperature

The FIREBAR element operates at a lower sheath temperature than a round tubular element of equal watt density because of three factors.

1. Flat Surface Geometry

FIREBAR's flat, vertical geometry is streamline. The liquid's flow past the heating element's surface is not impaired by back eddies inherent in the round tubular shape. The FIREBAR's streamline shape results in fluids flowing more freely with more heat carried away from the sheath.



2. Normal to the Flow

The element's width (thickness) of both 1 inch and 5/8 inch FIREBAR elements is just 0.235 in. (5.9 mm). Compared to a 0.430 in. (11 mm) round tubular element, this relative thinness further reduces drag on liquids or gases flowing past the heater.

3. Buoyancy Force

The FIREBAR element's boundary layer, or vertical side, is greater than virtually all round tubular elements. This is 1.010 and 0.650 in. (25.6 and 16.5 mm) for the one inch and 5/8 in. FIREBARs respectively, compared to a 0.430 in. (11 mm) diameter on a round tubular element. The FIREBAR element's increased height, relative to flow, increases the buoyancy force in viscous liquids. This buoyancy force can be as much as 10 times greater depending on the FIREBAR element and liquid used.

Comparative Widths

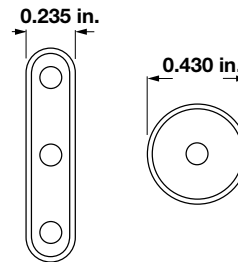

Watt Density and Surface Area Advantages

The surface area per linear inch of a 1 in. FIREBAR is 70 percent greater than the 0.430 in. (11 mm) diameter round tubular element. The 5/8 in. FIREBAR is nearly 10 percent greater.

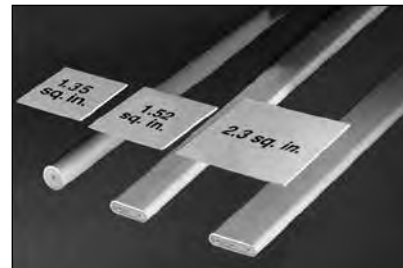

Element Type	Surface Area Per Linear Inch (cm)	
	in ²	cm ²
1 in. FIREBAR	2.30 in ²	(5.84 cm ²)
5/8 in. FIREBAR	1.52 in ²	(3.86 cm ²)
0.430 in. Round	1.35 in ²	(3.43 cm ²)

Flat vs. Round Geometry Comparisons

The unique flat surface geometry of the FIREBAR element offers more versatility in solving heater problems than the conventional round tubular element. The following comparisons show how the FIREBAR element consistently outperforms round tubular heaters. FIREBAR elements can:

- Reduce coking and fluid degrading
- Increase heater power within application space parameters
- Provide superior heat transfer in clamp-on applications resulting from greater surface area contact
- Lower watt density

Reducing watt density or sheath temperature extends life. The FIREBAR element allows you to do either, without sacrificing equipment performance ... as is proven by the accompanying *Heater Oil Test, Air Flow and Watt Density vs. Sheath Temperature* graphs.

Tubular Heaters



FIREBAR Single/Double-Ended Heaters

Technical Data

The *FIREBAR Heater Oil Test* graph compares sheath temperatures of 40 W/in² (6.7 W/cm²) flat and round tubular elements. The FIREBAR element consistently operates at a lower sheath temperature than the round tubular element, even when light oils are tested at different temperatures. This reduces the chance that coking and fluid degradation will occur.

In fact, the FIREBAR element's sheath temperature at 40 W/in² (6.7 W/cm²) is lower than a 30 W/in² (4.6 W/cm²) round tubular element.

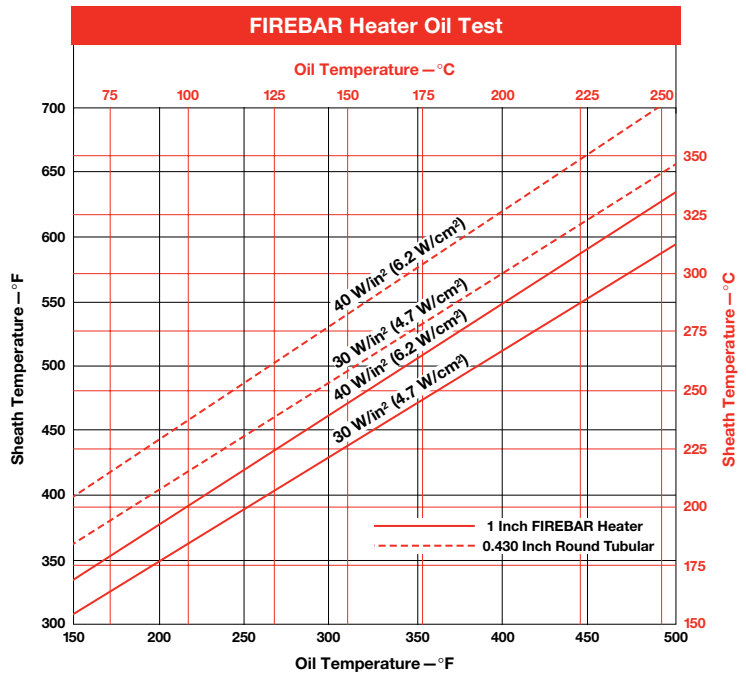

Heater Size and Power

The *Heater Size Comparison* chart shows, at the same wattage and watt density, the FIREBAR element is 38 percent shorter than a 0.430 in. (11 mm) round tubular element. The FIREBAR element requires less space in application and equipment designs.

Heater Size Comparison

Element	Heated Length in. (mm)	Wattage	W/in ²	(W/cm ²)
1 in. FIREBAR Element	19 ⁷ / ₈ (504.8)	1000	23	(3.6)
0.430 in. Round Tubular Element	32 ¹ / ₄ (819.0)	1000	23	(3.6)

The *Heater Power Comparison* chart demonstrates equal watt density, element length and increased total wattage for the FIREBAR element. The power in the FIREBAR element is 70 percent greater.

Heater Power Comparison

Element	Heated Length in. (mm)	Wattage	W/in ²	(W/cm ²)
1 in. FIREBAR Element	32 ¹ / ₄ (819.0)	1700	23	(3.6)
0.430 in. Round Tubular Element	32 ¹ / ₄ (819.0)	1000	23	(3.6)

Tubular Heaters



FIREBAR Single/Double-Ended Heaters

Technical Data (Continued)

Clamp-On Applications

Direct immersion in the liquid may not always be practical. In these instances the FIREBAR element can be clamped to a tank wall. Heat from the FIREBAR is conducted to the tank wall and into the media.

FIREBAR elements are also economical platen heaters. The *Platen Heating* graph shows FIREBAR's large, flat surface area allowing it to operate at twice the watt density of round tubular elements ... without sacrificing heater life.

Clamps should be placed approximately 6 in. (150 mm) apart and torqued down with 60 in.-lbs (6.8 Newton meters).

Platen Heating (°F)

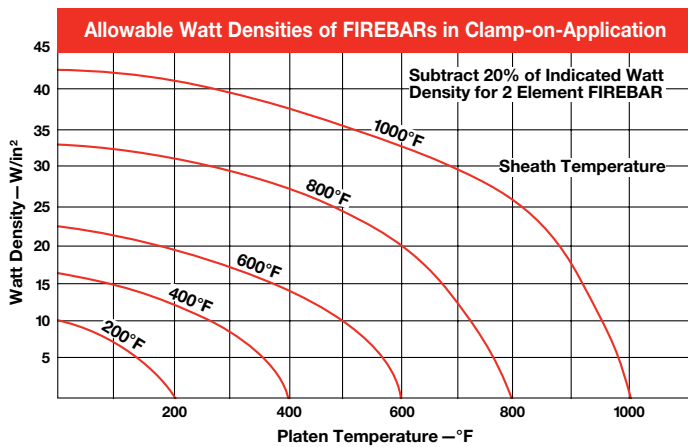

Platen Heating (°C)

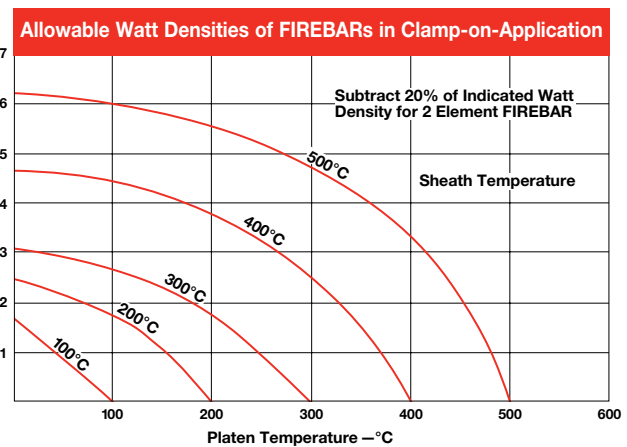

Watt Density vs. Sheath Temperature

The *Watt Density vs. Sheath Temperature* graph features sheath temperature curves for commonly heated substances. A FIREBAR element's watt density will result in the sheath temperature shown at the intersecting point of its vertical watt density line and substance curve.

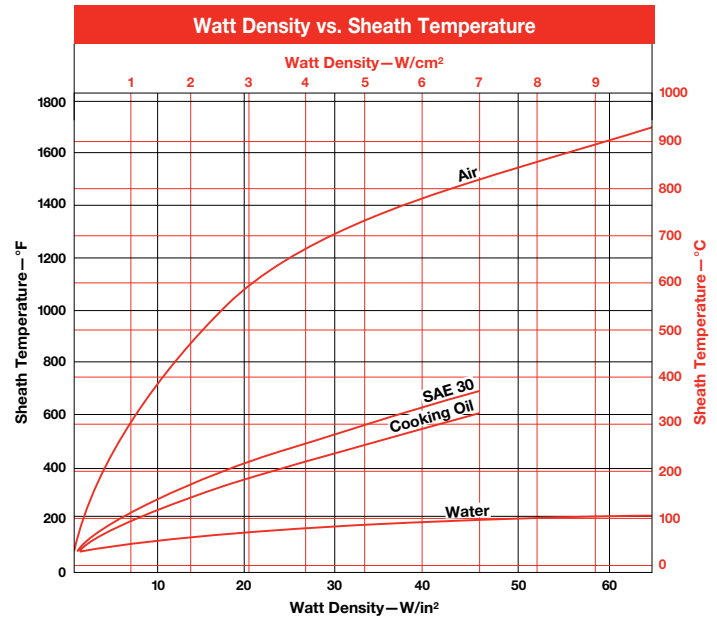

Tubular Heaters



FIREBAR Single/Double-Ended Heaters

Technical Data (Continued)

Air Heating

The Air Flow/Watt Density/Sheath Temperature graph shows the relationship between air flow, watt density and sheath temperature. Keep in mind that lower sheath temperature yields longer heater life.

To use the Air Flow graph, determine the air flow in feet per second (or meters per second). Then follow the curve to find the recommended sheath temperature and watt density.



Air Flow Normal to Sheath Geometry

Air Flow/Watt Density/Sheath Temperature (°F)

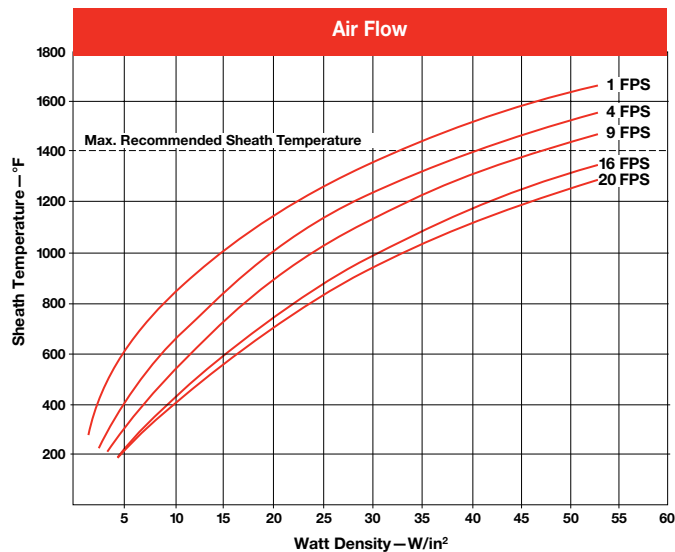

Air Flow/Watt Density/Sheath Temperature (°C)

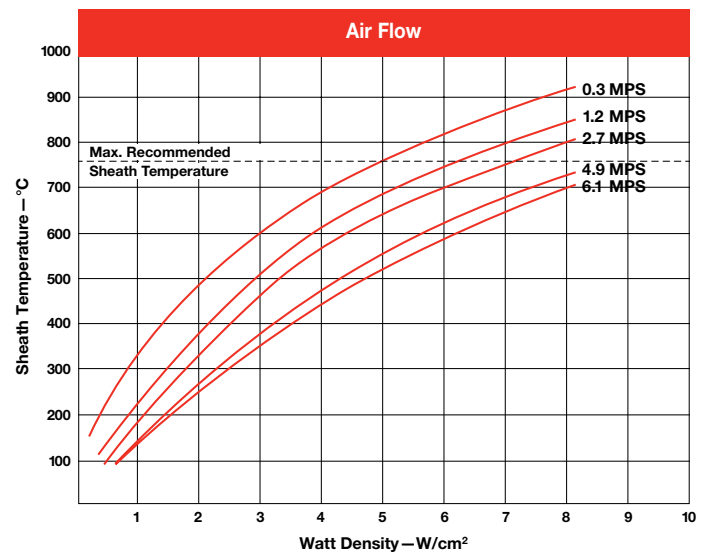

Moisture Resistant Seals

A lavacone seal is provided to prevent moisture and contaminants from entering the heater. Upon request, optional silicone rubber (RTV) and epoxy resin seals may be ordered.

Silicone Rubber (RTV) Seal

Silicone rubber RTV seals are 1/8 in. (3.2 mm) moisture barriers surrounding the terminal pins at the end of the sheath. Silicone rubber is effective to 392°F (200°C).

Epoxy Resin Seal

Epoxy resin seals are 1/8 in. (3.2 mm) moisture barriers surrounding the terminal pins at the end of the sheath. Epoxy resin is effective to 194°F (90°C) or 356°F (180°C), and recommended for water heating applications.

Application Hints

- Choose a FIREBAR heating element instead of an assembly when the application requires lower wattages or smaller system packages.
- Keep terminations clean, dry and tight.
- Extend the heated section completely into the media being heated at all times to maximize heat transfer and heater life.
- Do not locate the end of the heated length within a bend, unless the radius is 3 in. (76 mm) or larger.
- Ensure termination temperatures do not exceed 392°F (200°C) or the maximum temperature rating of the end seal, whichever is lower.

Tubular Heaters



FIREBAR Single/Double-Ended Heaters

Technical Data (Continued)

All FIREBAR heaters are available with a variety of termination options. Contact your Watlow representative for availability.

Terminations

Part Number*	Termination	Phase	Wiring	1 in. FIREBAR		5/8 in. FIREBAR	
				Dual-Ended	S. End/FINBAR	Dual-Ended	Single-Ended
A1	Sil-A-Blend® 200°C lead wire	1	Parallel	Yes	Yes	Yes	Yes
A2	Sil-A-Blend® 200°C lead wire	1	Series	Yes	No	Yes	No
A3	Sil-A-Blend® 200°C lead wire	3	Delta	Yes	No	No	No
A4	Sil-A-Blend® 200°C lead wire	3	Wye	Yes	Yes	No	No
B1	TGGT 250°C lead wire	1	Parallel	Yes	Yes	Yes	Yes
B2	TGGT 250°C lead wire	1	Series	Yes	No	Yes	No
B3	TGGT 250°C lead wire	3	Delta	Yes	No	No	No
B4	TGGT 250°C lead wire	3	Wye	Yes	Yes	No	No
C1	1/4 in. quick connect (spade)	1	Parallel	Yes	Yes	Yes	Yes
C2	1/4 in. quick connect (spade)	1	Series	Yes	No	No	No
D1	Screw lug (plate) terminal	1	Parallel	Yes	Yes	Yes	Yes
D2	Screw lug (plate) terminal	1	Series	Yes	No	No	No
D3	Screw lug (plate) terminal	3	Delta	Yes	No	No	No
E1	#10-32 stud terminal	1	Parallel	Yes	Yes	Yes	Yes
E2	#10-32 stud terminal	1	Series	Yes	No	No	No
E3	#10-32 stud terminal	3	Delta	Yes	No	No	No

Termination Code Number Legend*

- A = Silicone rubber insulation (Sil-A-Blend®) with fiberglass oversleeves Rated to 392°F (200°C)
- B = High-temperature TGGT insulation with fiberglass oversleeves Rated to 480°F (250°C)
- C = Nickel-plated steel quick connect

D = Nickel-plated steel screw lug with ceramic insulator and plated steel screw

E = #10-32 nickel-plated steel threaded stud with plated steel nuts and washers

Electrical Configuration

- 1 = 1-phase parallel, 2 = 1-phase series, 3 = 3-phase delta, 4 = 3-phase wye

Double-End/Single-End 1 in. FIREBAR

Flexible Lead Wire^① A, B

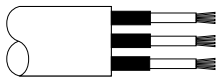

- Double-End 1 in. FIREBAR
- Single-End 1 in. FIREBAR
- FINBAR

Screw Lug (Plate) D1

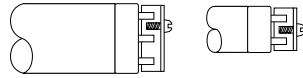

- Double-End 1 & 5/8 in. FIREBAR

Screw Lug (Plate) D3

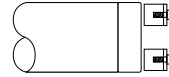

- Double-End 1 in. FIREBAR

3-phase delta wiring example

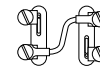

Threaded Stud E2

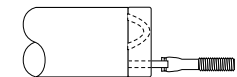

- Double-End 1 in. FIREBAR

Quick Connect (Spade) C2

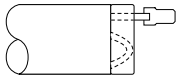

- Double-End 1 in. FIREBAR

Screw Lug (Plate) D2

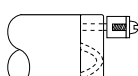

- Double-End 1 in. FIREBAR

Threaded Stud E1



- Double-End 1 & 5/8 in. FIREBAR

Threaded Stud E3

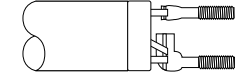

- Double-End 1 in. FIREBAR

3-phase delta wiring example

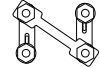

Single-End FIREBAR, Double-End/Single-End FINBAR

Flexible Lead Wire^① A, B

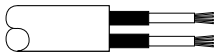

- Single-End 1 in. FIREBAR
- Double-End 5/8 in. FIREBAR
- Single-End 5/8 in. FIREBAR
- FINBAR

Quick Connect (Spade) C1

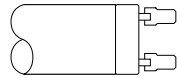

- Single-End 1 FIREBAR
- FINBAR
- Double-End 5/8 in. FIREBAR
- Single-End 5/8 in. FIREBAR

Screw Lug (Plate) D1

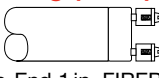

- Single-End 1 in. FIREBAR
- FINBAR
- Double-End 5/8 in. FIREBAR
- Single-End 5/8 in. FIREBAR

Threaded Stud E1

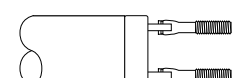

- Single-End 1 in. FIREBAR
- FINBAR

^①Flexible lead wires are 12 in. (305 mm) long unless otherwise specified.

Tubular Heaters



FIREBAR Single/Double-Ended Heaters

Bending

Major and Minor Axis Bending Parameters

The following illustrations detail the recommended major and minor axis bend parameters for FIREBAR elements. These illustrations show the relationship between the type of bend and the location of heat and no-heat sections. See the next two pages for the 15 common bend formations.

Note: Watlow does not recommend field bending FIREBAR elements. If the element must be bent in the field, please contact your Watlow representative for assistance.

180° Minor Axis Heated Bend

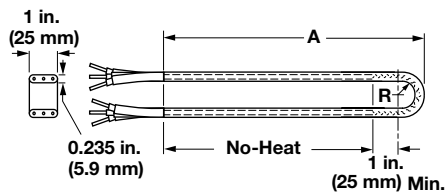

180° Major Axis Heated Bend

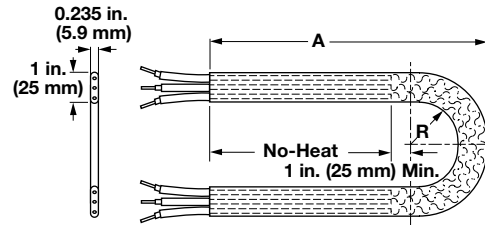

90° Minor Axis Heated Bend

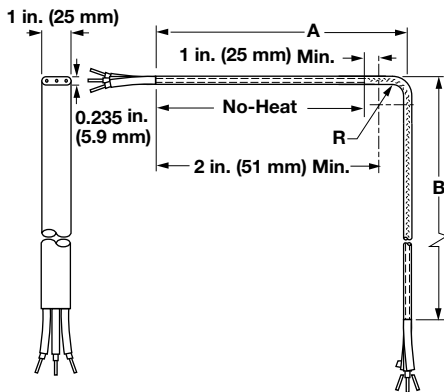

90° Major Axis Heated Bend

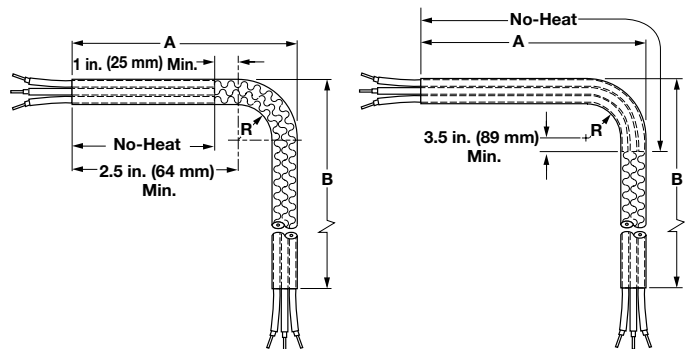

90° Minor Axis Un-Heated Bend

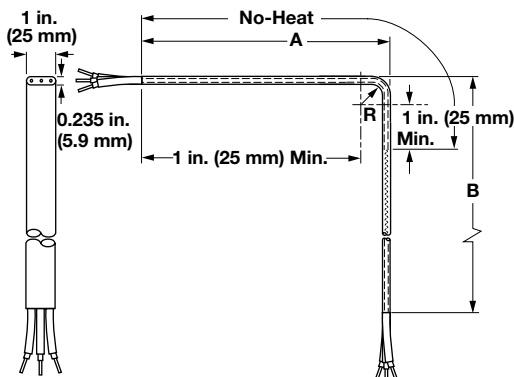

180° Major Axis Bends

FIREBAR Size in.	(mm)	Radius in.	(mm)	Arc Length
5/8	(15.9)	3/4	(19.0)	3.125
5/8	(15.9)	1	(25.0)	3.900
5/8	(15.9)	1 1/4	(32.0)	4.620
5/8	(15.9)	1 1/2	(38.0)	5.600
1	(25.0)	1	(25.0)	4.335
1	(25.0)	1 1/4	(32.0)	5.121
1	(25.0)	1 1/2	(38.0)	5.906

Tubular Heaters



FIREBAR Single/Double-Ended Heaters

Bend Formations

FIREBAR elements can be formed into compounds, multi-axis and multi-plane configurations from 15 common bends. Custom bending with tighter tolerances can be made to meet specific application needs.

Formation is limited by bending parameters specified in the illustrations of major and minor axis bends on the previous page. On these illustrations, please note the no-heat end location.

The no-heat end junction must be located a minimum of 1 in. (25 mm) from any bend. If these parameters are not followed, the heater may fail prematurely. Field bending not recommended.

Illustrated below are the common bends that can be ordered for all FIREBAR heating elements.

To order a common bend, specify the **figure number** and **critical dimensions**.

Note: The alpha characters and symbols are used to designate specific dimensions within each illustration.

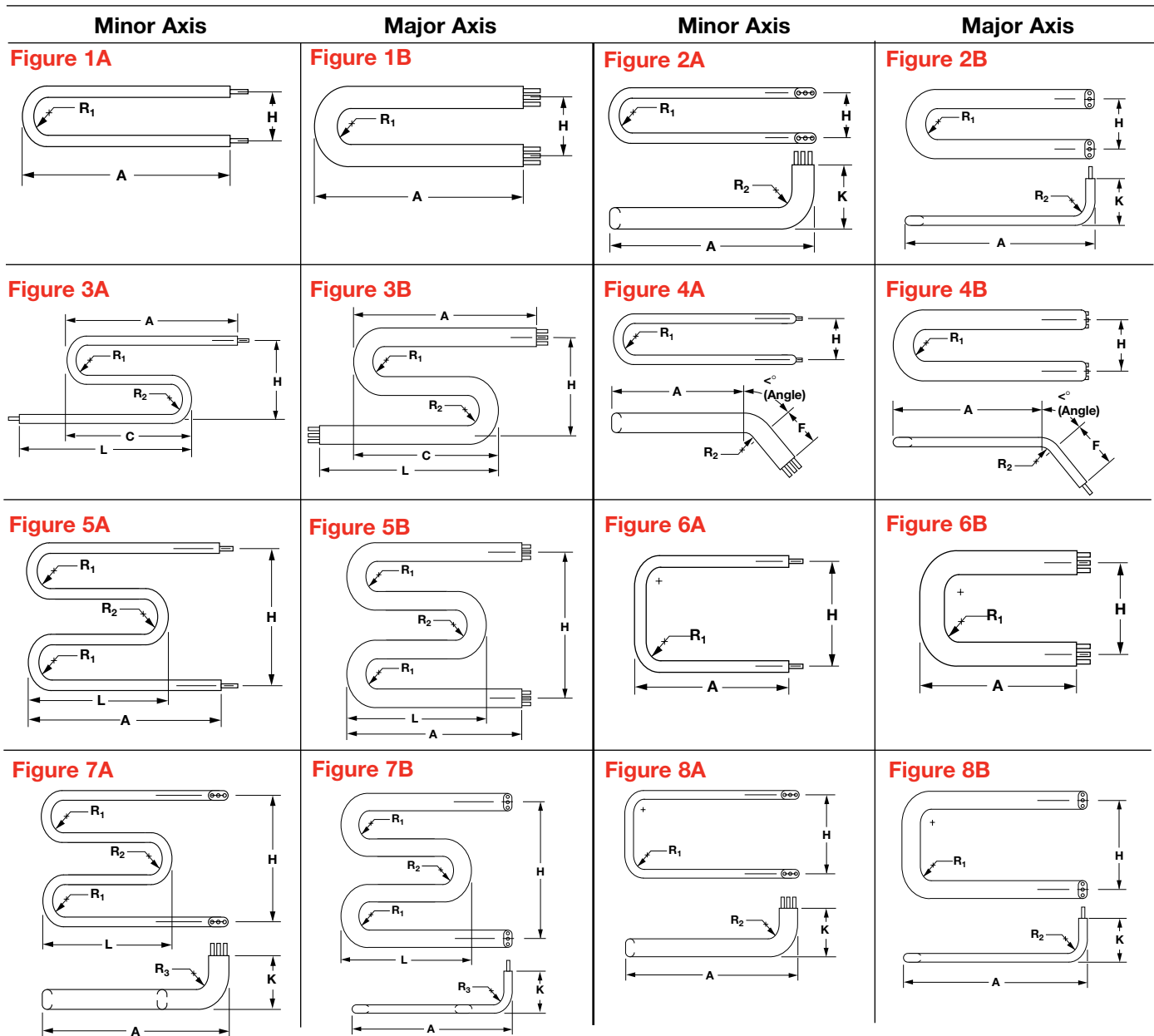

Tubular Heaters



FIREBAR Single/Double-Ended Heaters

Bend Formation (Continued)

Minor Axis	Major Axis	Minor Axis	Major Axis
<p>Figure 9A</p>	<p>Figure 9B</p>	<p>Figure 10A</p>	<p>Bend Figure 10B Not Available On Major Axis</p>
<p>Figure 11A</p>	<p>Bend Figure 11B Not Available On Major Axis</p>	<p>Figure 12A</p>	<p>Figure 12B</p>
<p>Figure 13A</p>	<p>Figure 13B</p>	<p>Figure 14A</p>	<p>Figure 14B</p>
<p>Figure 15A</p>	<p>Figure 15B</p>		

Tubular Heaters



FIREBAR Single/Double-Ended Heaters

Mounting Brackets

Steel brackets provide element mounting in non-pressurized applications. In air heating applications, an 18-gauge aluminized steel bracket is tack welded to the element. A 1/4 in. (6 mm) thick steel bracket is brazed or welded liquid-tight to the element for liquid heating. Upon request, stainless steel brackets can be provided. Special sizes also available.

The bracket is located 1/2 in. (13 mm) from the sheath's end, 1/16 in. (1.6 mm) if welded. Available on 5/8 in. (15.9 mm) FIREBAR as **made-to-order** only.

To order, specify **mounting bracket** as well as type, location, material and size.

Type 1

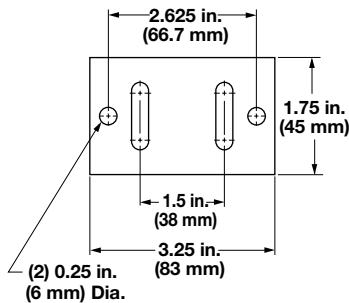

Type 2

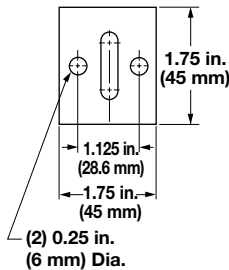

Type 3

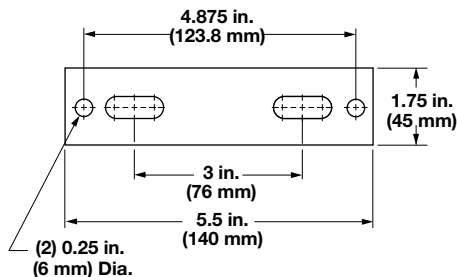

Water-Tight Double-Leg Threaded Fitting

A threaded 1 5/8 in.-10 UNC stainless steel fitting with flange on the heater sheath provides rigid, leak-proof mounting through tank walls. This fitting allows both legs of the heater to pass through the same opening. A gasket, plated steel washer and hex nut are included. The threaded end of the bulkhead is mounted flush with the sheath's end, unless otherwise specified. Available on **1 inch FIREBAR only (brazed only, available)**.

To order, specify **water-tight double-leg threaded fitting**.

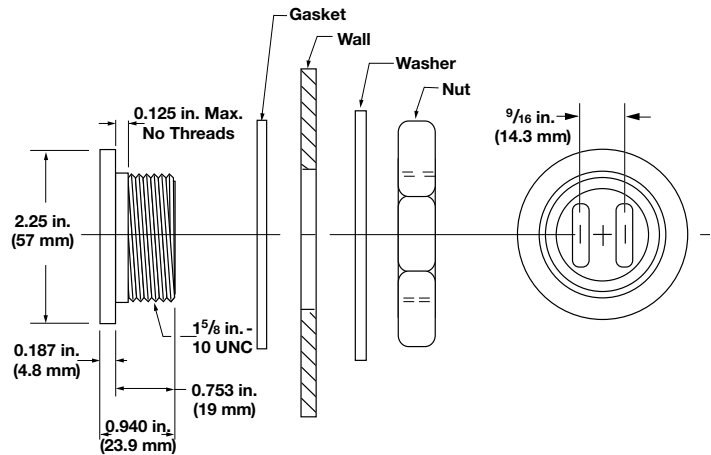

Surface Finish

Bright Annealing

Bright annealing is a process that produces a smooth, metallic finish. It is a special annealed finish created in a non-oxidizing atmosphere. This finish is popular in the pharmaceutical and foodservice/beverage markets.

To order, specify **bright annealing**.

Passivation

During manufacturing, particles of iron or tool steel may be embedded in the stainless steel or alloy sheath. If not removed, these particles may corrode and produce rust spots. For critical sheath applications, passivation will remove free iron from the sheath.

To order, specify **passivation**.

Tubular Heaters

**EXTENDED
CAPABILITY**



Extended Capabilities for FIREBAR Single/Double-Ended Heaters

Single Leg Threaded Bulkhead

A threaded stainless steel bushing with flange on the heater sheath provides rigid, leak-proof mounting through tank walls. A gasket, plated steel washer and hex nut are included (brazed only, available).

To order, specify **single leg threaded bulkhead**.

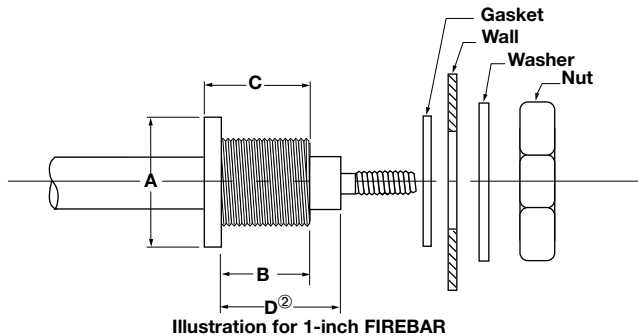

Heater Size in.	(mm)	Thread Size
5/8	(15.9)	7/8-14 UNF-2A
1	(25.0)	3/4-16 UNF-2A

Illustration for 5/8-inch FIREBAR

Options for One-Inch and 5/8-Inch FIREBAR

- Electropolished finish
- Bulkhead, single leg
- Custom formations
- Terminal enclosures (general purpose, moisture resistant, and moisture/corrosion resistant)
- Custom wattage tolerance ($\pm 5\%$)

Tubular Heaters



FIREBAR Single/Double-Ended Heaters

One-Inch, Double-Ended FIREBAR

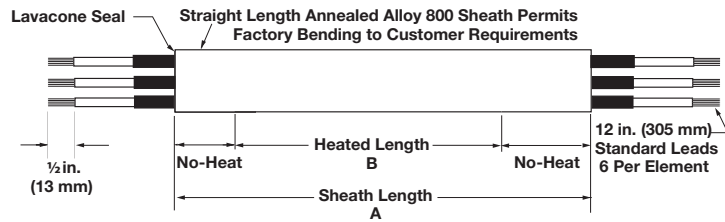

FIREBAR Description	Sheath A Dimension		Heated B Dimension		Watts	Part Number		Est. Net Wt.	
	in.	(mm)	in.	(mm)		120VAC	240VAC	lbs	(kg)

Applications: Asphalt, Paraffin (Solid), Bunker Oil, Clamp-On

6 W/in² Alloy 800 (1 W/cm²)	35	(889)	25	(635)	310	FBN351WD-1		1.3	(0.6)
	41	(1041)	31	(787)	410	FBN411WD-1		1.5	(0.7)
	51	(1295)	41	(1041)	530	FBN511WD-1	FBN5110WD-1	1.9	(0.9)
	62	(1574)	52	(1320)	650	FBN621WD-1	FBN6210WD-1	2.3	(1.1)
	72	(1828)	62	(1574)	800	FBN721WD-1	FBN7210WD-1	2.6	(1.2)
	93	(2362)	83	(2108)	1,060	FBN931WD-1	FBN9310WD-1	3.4	(1.6)
	114	(2895)	104	(2641)	1,350	FBN1141WD-1	FBN11410WD-1	4.2	(1.9)

Applications: Griddles, Fuel Oil, Clamp-On

10 W/in² Alloy 800 (1.6 W/cm²)	25	(635)	22	(558)	500	FBN251WL-1		0.9	(0.4)
	35	(889)	32	(812)	750	FBN351WL-1	FBN3510WL-1	1.3	(0.6)
	47	(1193)	43	(1092)	1,000	FBN471WL-1	FBN4710WL-1	1.7	(0.8)
	69	(1752)	65	(1651)	1,500	FBN691WL-1	FBN6910WL-1	2.5	(1.2)
	90	(2286)	86	(2184)	2,000	FBN901WL-1	FBN9010WL-1	3.3	(1.5)

Applications: Clamp-On, Medium Weight Oils, Liquid Paraffin, Low-Temperature Ovens 400°F (205°C)

15 W/in² ① Alloy 800 (2.3 W/cm²)	29	(736)	19	(482)	670		FBN2910WE-1	1.1	(0.5)
	34	(863)	24	(609)	830		FBN3410WE-1	1.3	(0.6)
	39	(990)	29	(736)	1,000		FBN3910WE-1	1.4	(0.7)
	48	(1219)	38	(965)	1,330		FBN4810WE-1	1.8	(0.9)
	58	(1473)	48	(1219)	1,670		FBN5810WE-1	2.1	(1.0)
	68	(1727)	58	(1473)	2,000		FBN6810WE-1	2.5	(1.2)
	87	(2209)	77	(1955)	2,670		FBN8710WE-1	3.2	(1.5)
	106	(2692)	96	(2438)	3,330		FBN10610WE-1	3.9	(1.8)

Applications: Radiant, Platens, Dies, Low-Temperature Ovens 300°F (150°C)

20 W/in² Alloy 800 (3.1 W/cm²)	15	(381)	11	(279)	500	FBN151WM-1		0.6	(0.3)
	20	(508)	16	(406)	750	FBN201WM-1		0.8	(0.4)
	26	(660)	22	(558)	1,000	FBN261WM-1	FBN2610WM-1	1.0	(0.5)
	36	(914)	32	(812)	1,500	FBN361WM-1	FBN3610WM-1	1.3	(0.6)
	48	(1219)	43	(1092)	2,000	FBN481WM-1	FBN4810WM-1	1.8	(0.9)
	70	(1778)	65	(1651)	3,000		FBN7010WM-1	2.6	(1.2)
	91	(2311)	85	(2159)	4,000		FBN9110WM-1	3.3	(1.5)

Applications: Degreasing Solutions, Heat Transfer Oils

23 W/in² Alloy 800 (3.6 W/cm²)	35	(889)	25	(635)	1,250	FBN351WT-1	FBN3510WT-1	1.3	(0.6)
	41	(1041)	31	(787)	1,625	FBN411WT-1	FBN4110WT-1	1.5	(0.7)
	51	(1295)	41	(1041)	2,125	FBN511WT-1	FBN5110WT-1	1.9	(0.9)
	62	(1574)	52	(1320)	2,625	FBN621WT-1	FBN6210WT-1	2.3	(1.1)
	72	(1828)	62	(1574)	3,200	FBN721WT-1	FBN7210WT-1	2.6	(1.2)
	93	(2362)	83	(2108)	4,250	FBN931WT-1	FBN9310WT-1	3.4	(1.6)
	114	(2895)	104	(2641)	5,400	FBN1141WT-1	FBN11410WT-1	4.2	(1.9)

CONTINUED

Tubular Heaters



FIREBAR Single/Double-Ended Heaters

One-Inch, Double-Ended FIREBAR (Continued)

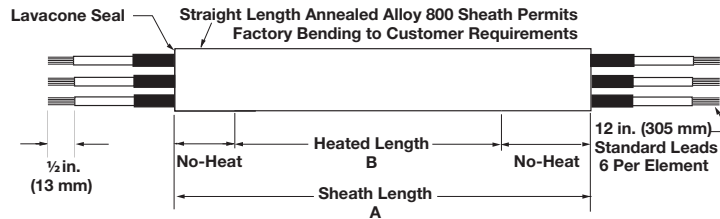

FIREBAR Description	Sheath A Dimension		Heated B Dimension		Watts	Part Number		Est. Net Wt.	
	in.	(mm)	in.	(mm)		120VAC	240VAC	lbs	(kg)

Applications: Cooking Oils, Mild Caustic Solution, Ethylene Glycol (100%)

30 W/in ² Alloy 800 (4.7 W/cm ²)	16	(406)	10	(254)	750	FBN161WH-1		0.6	(0.3)
	20	(508)	14	(355)	1000	FBN201WH-1		0.8	(0.4)
	27	(685)	21	(533)	1500	FBN271WH-1	FBN2710WH-1	1.0	(0.5)
	34	(863)	28	(711)	2000	FBN341WH-1	FBN3410WH-1	1.3	(0.6)
	50	(1270)	43	(1092)	3000		FBN5010WH-1	1.8	(0.9)
	64	(1625)	57	(1447)	4000		FBN6410WH-1	2.4	(1.1)
	80	(2032)	72	(1828)	5000		FBN8010WH-1	2.9	(1.4)

Applications: Process Water, Ethylene Glycol (50%)

40 W/in ² Alloy 800 (6.2 W/cm ²)	25	(635)	22	(558)	2000		FBN2510WK-1	0.9	(0.4)
	35	(889)	32	(812)	3000		FBN3510WK-1	1.3	(0.6)
	47	(1193)	43	(1092)	4000		FBN4710WK-1	1.7	(0.8)
	69	(1752)	65	(1651)	6000		FBN6910WK-1	2.5	(1.2)
	90	(2286)	86	(2184)	8000		FBN9010WK-1	3.3	(1.5)
45 W/in ² Alloy 800 (7 W/cm ²)	29	(736)	19	(482)	2000		FBN2910WP-1	1.1	(0.5)
	34	(863)	24	(609)	2500		FBN3410WP-1	1.3	(0.6)
	39	(990)	29	(736)	3000		FBN3910WP-1	1.4	(0.7)
	48	(1219)	38	(965)	4000		FBN4810WP-1	1.8	(0.9)
	58	(1473)	48	(1219)	5000		FBN5810WP-1	2.1	(1.0)
	68	(1727)	58	(1473)	6000		FBN6810WP-1	2.5	(1.2)
	87	(2209)	77	(1955)	8000		FBN8710WP-1	3.2	(1.5)
106	(2692)	96	(2438)	10,000		FBN10610WP-1	3.9	(1.8)	

Applications: Clean and Potable Water

80 W/in ² Alloy 800 (12.4 W/cm ²)	15	(381)	11	(279)	2000		FBN1510WJ-1	0.6	(0.3)
	20	(508)	16	(406)	3000		FBN2010WJ-1	0.8	(0.4)
	26	(660)	22	(558)	4000		FBN2610WJ-1	1.0	(0.5)
	36	(914)	32	(812)	6000		FBN3610WJ-1	1.3	(0.6)
	48	(1219)	43	(1092)	8000		FBN4810WJ-1	1.8	(0.9)
	70	(1778)	65	(1651)	12,000			2.6	(1.2)
90 W/in ² Alloy 800 (14 W/cm ²)	91	(2311)	85	(2159)	16,000			3.3	(1.5)
	35	(889)	25	(635)	5000	FBN351WG-1	FBN3510WG-1	1.3	(0.6)
	41	(1041)	31	(787)	6500	FBN411WG-1	FBN4110WG-1	1.5	(0.7)
	51	(1295)	41	(1041)	8500		FBN5110WG-1	1.9	(0.9)
	62	(1574)	52	(1320)	10,500		FBN6210WG-1	2.3	(1.1)
	72	(1828)	62	(1574)	12,750		FBN7210WG-1	2.6	(1.2)
	93	(2362)	83	(2108)	17,000			3.4	(1.6)
114	(2895)	104	(2641)	21,500			3.4	(1.6)	

Tubular Heaters



FIREBAR Single/Double-Ended Heaters

5/8-Inch Double-Ended FIREBAR

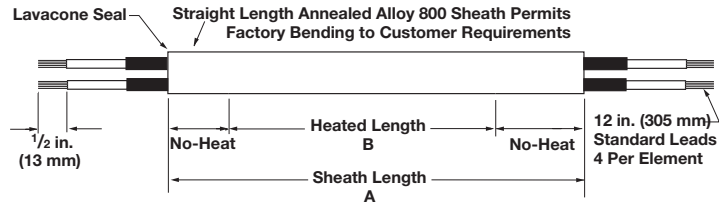

FIREBAR Description	Sheath A Dimension		Heated B Dimension		Watts	Part Number		Est. Net Wt.	
	in.	(mm)	in.	(mm)		120VAC	240VAC	lbs	(kg)

Applications: Degreasing Fluids, Heat Transfer Oils

23 W/in² ① Alloy 840 (3.6 W/cm²)	19	(483)	11	(279)	375	FAN191WT-1		0.5	(0.3)
	22	(559)	14	(356)	500	FAN221WT-1	FAN2210WT-1	0.5	(0.3)
	26	(660)	18	(457)	625	FAN261WT-1	FAN2610WT-1	0.6	(0.3)
	30	(762)	22	(559)	750	FAN301WT-1	FAN3010WT-1	0.7	(0.4)
	37	(940)	29	(737)	1000	FAN371WT-1	FAN3710WT-1	0.9	(0.5)
	44	(1118)	36	(914)	1250	FAN441WT-1	FAN4410WT-1	1.0	(0.5)
	51	(1295)	43	(1092)	1500	FAN511WT-1	FAN5110WT-1	1.2	(0.6)

Applications: Clean and Potable Water

90 W/in² Alloy 840 (14 W/cm²)	15	(381)	7	(178)	1000	FAN151WG-1	FAN1510WG-1	0.4	(0.2)
	19	(483)	11	(279)	1500	FAN191WG-1	FAN1910WG-1	0.5	(0.3)
	22	(559)	14	(356)	2000	FAN221WG-1	FAN2210WG-1	0.5	(0.3)
	26	(660)	18	(457)	2500	FAN261WG-1	FAN2610WG-1	0.6	(0.3)
	30	(762)	22	(559)	3000	FAN301WG -1	FAN3010WG-1	0.7	(0.4)
	37	(940)	29	(737)	4000		FAN3710WG-1	0.9	(0.5)
	44	(1118)	36	(914)	5000		FAN4410WG-1	1.0	(0.5)
	51	(1295)	43	(1092)	6000		FAN5110WG-1	1.2	(0.6)

Tubular Heaters



FIREBAR Single/Double-Ended Heaters

One-Inch, Single-Ended FIREBAR

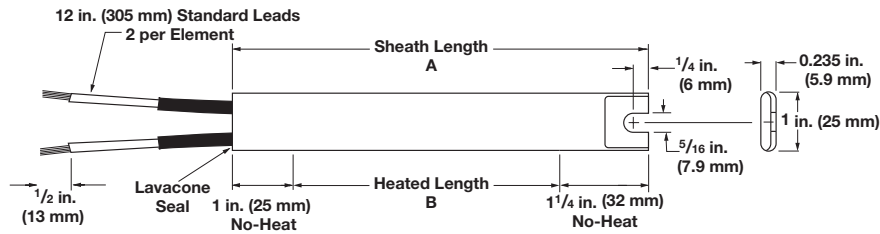

FIREBAR Description	Sheath A Dimension		Heated B Dimension		Watts	Part Number		Est. Net Wt.	
	in.	(mm)	in.	(mm)		120VAC	240VAC	lbs	(kg)

Applications: Radiant, Platens, Dies, Low-Temperature Ovens 300°F (150°C)

20 W/in ² 304 SS (3.1 W/cm ²)	8 ³ / ₄	(222.0)	6 ¹ / ₂	(165.0)	300	FSP91WM-1		0.4	(0.2)
	10 ¹ / ₄	(260.0)	7 ¹ / ₂	(203.0)	375	FSP101WM-1		0.4	(0.2)
	12 ¹ / ₄	(311.0)	10	(254.0)	450	FSP121WM-1		0.5	(0.3)
	13 ¹ / ₂	(343.0)	11 ¹ / ₄	(286.0)	500	FSP141WM-1		0.5	(0.3)
	16 ¹ / ₈	(408.6)	13 ⁷ / ₈	(352.4)	650	FSP161WM-1	FSP1610WM-1	0.6	(0.3)
	17 ³ / ₄	(451.0)	15 ¹ / ₂	(393.0)	725	FSP181WM-1	FSP1810WM-1	0.7	(0.4)
	19 ¹ / ₄	(489.0)	17	(431.0)	800	FSP191WM-1	FSP1910WM-1	0.7	(0.4)
	22	(558.0)	19 ³ / ₄	(502.0)	900	FSP221WM-1	FSP2210WM-1	0.8	(0.4)
	23 ³ / ₄	(603.0)	21 ¹ / ₂	(546.0)	1,000	FSP241WM-1	FSP2410WM-1	0.9	(0.4)
	25	(635.0)	22 ³ / ₄	(578.0)	1,050	FSP251WM-1	FSP2510WM-1	0.9	(0.4)
	28 ⁵ / ₈	(727.1)	26 ³ / ₈	(670.0)	1,250	FSP291WM-1	FSP2910WM-1	1.1	(0.5)
	31 ⁵ / ₈	(803.3)	29 ³ / ₈	(746.1)	1,350	FSP321WM-1	FSP3210WM-1	1.2	(0.6)
	34 ¹ / ₈	(866.8)	31 ⁷ / ₈	(809.6)	1,500		FSP3410WM-1	1.3	(0.6)
	36 ⁷ / ₈	(936.6)	34 ⁵ / ₈	(879.5)	1,600		FSP3710WM-1	1.4	(0.7)
	40 ⁵ / ₈	(1031.9)	38 ³ / ₈	(974.7)	1,800		FSP4110WM-1	1.5	(0.7)
	46 ¹ / ₄	(1175.0)	44	(1117.0)	2,000		FSP4610WM-1	1.7	(0.8)

Applications: Air Heating

40 W/in ² 304 SS (6.2 W/cm ²)	8 ³ / ₄	(222.0)	6 ¹ / ₂	(165.0)	600	FSP91WK-1		0.4	(0.2)
	10 ¹ / ₄	(260.0)	7 ¹ / ₂	(203.0)	750	FSP101WK-1		0.4	(0.2)
	12 ¹ / ₄	(311.0)	10	(254.0)	900	FSP121WK-1	FSP1210WK-1	0.5	(0.3)
	13 ¹ / ₂	(343.0)	11 ¹ / ₄	(286.0)	1,000	FSP131WK-1	FSP1310WK-1	0.5	(0.3)
	16 ¹ / ₄	(413.0)	13 ⁷ / ₈	(352.4)	1,300	FSP161WK-1	FSP1610WK-1	0.6	(0.3)
	17 ³ / ₄	(451.0)	15 ¹ / ₂	(393.0)	1,450	FSP181WK-1	FSP1810WK-1	0.7	(0.4)
	19 ¹ / ₄	(489.0)	17	(431.0)	1,600		FSP1910WK-1	0.7	(0.4)
	22	(558.0)	19 ³ / ₄	(502.0)	1,800		FSP2210WK-1	0.8	(0.4)
	23 ³ / ₄	(603.0)	21 ¹ / ₂	(546.0)	2,000		FSP2410WK-1	0.9	(0.4)
	25	(635.0)	22 ³ / ₄	(578.0)	2,100		FSP2510WK-1	0.9	(0.4)
	28 ⁵ / ₈	(727.1)	26 ³ / ₈	(669.9)	2,500		FSP2910WK-1	1.1	(0.5)
	31 ⁵ / ₈	(803.2)	29 ³ / ₈	(746.1)	2,700		FSP3210WK-1	1.2	(0.6)
	34 ¹ / ₈	(866.8)	31 ⁷ / ₈	(809.6)	3,000		FSP3410WK-1	1.3	(0.6)
	36 ⁷ / ₈	(936.6)	34 ⁵ / ₈	(879.5)	3,200		FSP3710WK-1	1.4	(0.7)
	40 ⁵ / ₈	(1031.9)	38 ³ / ₈	(974.7)	3,600		FSP4110WK-1	1.5	(0.7)
	46 ¹ / ₄	(1175.0)	44	(1117.0)	4,000		FSP4610WK-1	1.7	(0.8)

Tubular Heaters



FIREBAR Single/Double-Ended Heaters

5/8-Inch Single-Ended FIREBAR

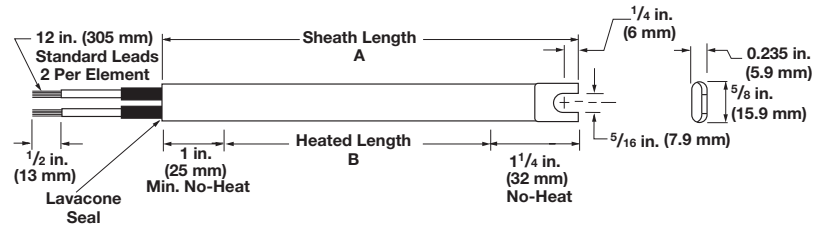

FIREBAR Description	Sheath A Dimension		Heated B Dimension		Watts	Part Number		Est. Net Weight	
	in.	(mm)	in.	(mm)		120VAC	240VAC	lbs	(kg)

Applications: Radiant, Platens, Dies, Low-Temperature Ovens 300°F (150°C)

20 W/in ²	11 1/2	(292)	8	(203)	250	FSA121WM-1		0.3	(0.2)
Alloy 840	15 1/2	(394)	12	(304)	375	FSA161WM-1	FSA1610WM-1	0.4	(0.2)
(3.1 W/cm ²)	19 1/2	(495)	16	(406)	500	FSA201WM-1	FSA2010WM-1	0.5	(0.3)
	28	(711)	24	(609)	750	FSA281WM-1	FSA2810WM-1	0.6	(0.3)
	36	(914)	32	(812)	1,000	FSA361WM-1	FSA3610WM-1	0.8	(0.4)
	52	(1321)	48	(1219)	1,500	FSA521WM-1	FSA5210WM-1	1.2	(0.6)

Tubular Heaters



FINBAR™ Single-Ended Heaters

Composed of aluminized steel fins press fitted to a one-inch single-ended FIREBAR element. The FINBAR™ is designed to improve heat transfer to the air and permits putting more power in tighter spaces—like forced air ducts, dryers, ovens and load bank resistors.

Heat transfer, lower sheath temperature and element life are all maximized by its finned construction. Installation is simplified by terminations exiting at one end and mounting accommodations on both ends.

Performance Capabilities

- Watt densities up to 50 W/in² (7.7 W/cm²)
- 304 stainless steel sheath temperatures up to 1200°F (650°C)
- Voltages up to 480VAC
- Amperages up to 48 amperes per heater or 16 amperes per coil

Features and Benefits

Rugged aluminized steel fins

- Provides an increase in surface area to approximately 16 square inches for every linear inch of element length. Fins press fitted to the heating element improve heat transfer to the air

Single-ended termination

- Simplifies wiring and installation

Stainless steel mounting bracket, welded to the terminal end, supplied with a slotted end

- Allows ease of installation

Lavacone seals

- Provides protection against humid storage conditions, moisture retardant to 221°F (105°C)

Typical Applications

- Forced air heating for dryers, ovens, ducts
- Still air heating for ovens, comfort heating
- Incubators
- Ink drying
- Load bank resistors

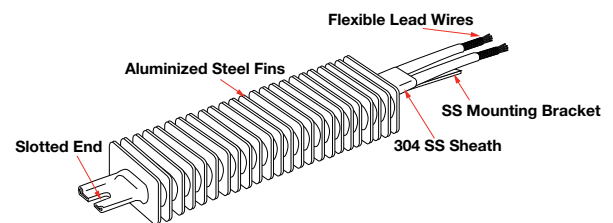

Construction Features

Watt Density: Up to 40 W/in² (6.2 W/cm²)

Fin Surface Area: 16 in²/linear in. (40.5 cm²/linear cm)

Fin Cross Section: 2 x 1 in. (50 x 25 mm)

Maximum Operating Temperature: Sheath material: 304 SS, 1200°F (650°C), fin material; aluminized steel; 1100°F (600°C)

Heater Length: 11 to 120 in. (280 to 3050 mm)

No-Heat Length: 1 in. (25 mm) min., 12 in. (305 mm) max.

Voltages: Up to 240VAC

Phase: 1-phase parallel or 3-phase wye

Resistance Coils: 1 or 3

Terminations: Flexible lead wires, quick connect (spade), screw lug (plate) and threaded stud

Seal Material: Lavacone, rated to 221°F (105°C)

Single-End Configuration: Slotted

Tubular Heaters



FINBAR Single-Ended Heaters

Air Heating

The *Watt Density, Air Flow and Sheath Temperature* graph shows the relationship between watt density, air flow velocity and sheath temperature, along with a recommended temperature to avoid deteriorating the fins. Be aware that **lower sheath temperature yields longer heater life**.

The graphic representation is based on a single-ended FINBAR, various air velocities (at 68°F/20°C inlet temperature) and different watt densities.

To determine, from the graph, the operating temperature of the FINBAR's sheath, identify the air velocity curve that approximates your application in feet per second (meters per second). Then, look at the vertical line that most closely approximates the FINBAR's watt density. From the intersecting point, read over to the temperature column to determine the sheath's operating temperature.

Watt Density, Air Flow and Sheath Temperature (°F)

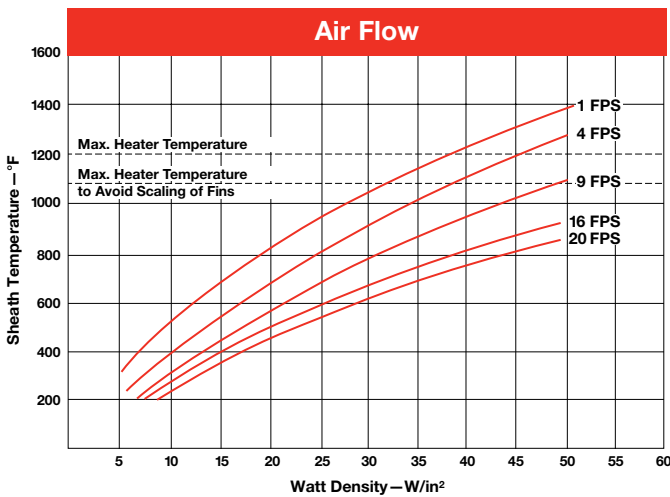

Watt Density, Air Flow and Sheath Temperature (°C)

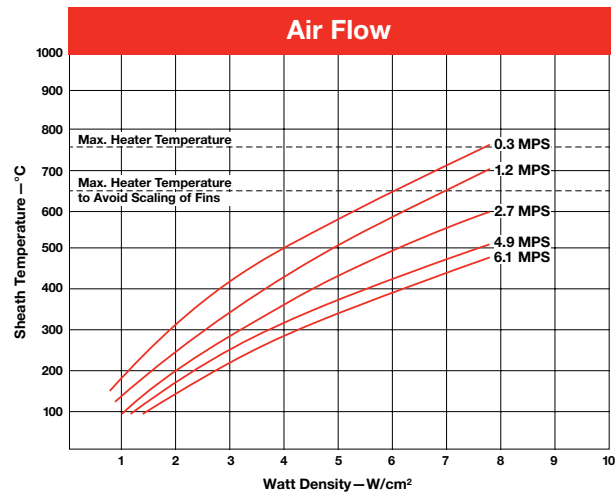

Dual Ended FINBAR

FINBAR elements are typically terminated at one end. Upon request, however, dual-ended FINBAR heaters can be ordered. To order, specify **dual-ended FINBAR** and lead length.

Application Hints

- Avoid deteriorating the fins by not exceeding the recommended maximum fin temperature of 1100°F (600°C).
- Ensure proper air flow to prevent premature heater failure.
- Locate the temperature sensor downstream from heater(s) for process temperature sensing.

The following mounting parameters are recommended:

- Air flow over element must be parallel with the flat side.
- Element center line to element center line spacing must be a minimum of 1½ in. (38 mm).

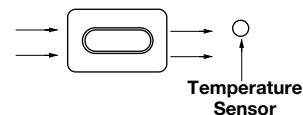

Proper air flow relative to the heater's sheath is parallel with the longer cross sectional axis.

Tubular Heaters



FINBAR Single-Ended Heaters

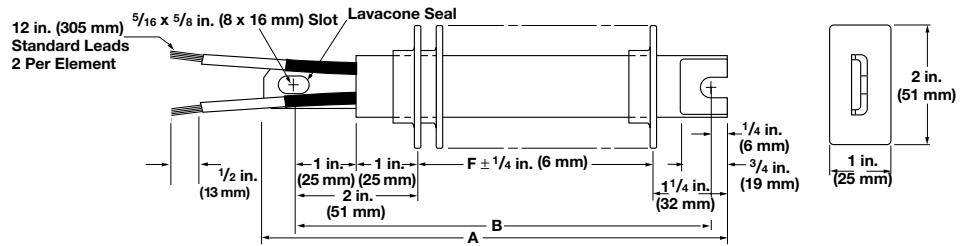

FINBAR Description	Overall A Dimension		Overall F Dimension		Mounting B Dimension		Watts	Part Number		Est. Net Wt.	
	in.	(mm)	in.	(mm)	in.	(mm)		120VAC	240VAC	lbs	(kg)
Application: Forced Air											
20 W/in² 304 SS (3.1 W/cm²)	10 ¹ / ₄	(260.0)	6 ¹ / ₂	(158.0)	9 ¹ / ₂	(241.0)	300	FSP91WMF		1.4	(0.7)
	11 ³ / ₄	(298.0)	8	(203.0)	11	(279.0)	375	FSP101WMF		1.4	(0.7)
	13 ³ / ₄	(349.0)	10	(254.0)	13	(330.0)	450	FSP121WMF		1.5	(0.7)
	15	(381.0)	11 ¹ / ₄	(285.0)	14 ¹ / ₄	(362.0)	500	FSP141WMF		1.5	(0.7)
	17 ⁵ / ₈	(447.7)	13 ⁷ / ₈	(352.4)	16 ⁷ / ₈	(428.6)	650	FSP161WMF	FSP1610WMF	1.6	(0.8)
	19 ¹ / ₄	(489.0)	15 ¹ / ₂	(393.0)	18 ¹ / ₂	(469.0)	725	FSP181WMF	FSP1810WMF	1.7	(0.8)
	20 ³ / ₄	(527.0)	17	(431.0)	20	(508.0)	800	FSP191WMF	FSP1910WMF	1.7	(0.8)
	23 ¹ / ₂	(597.0)	19 ³ / ₄	(501.0)	22 ³ / ₄	(577.0)	900	FSP221WMF	FSP2210WMF	1.8	(0.9)
	25 ¹ / ₄	(641.0)	21 ¹ / ₂	(546.0)	24 ¹ / ₂	(622.0)	1000	FSP241WMF	FSP2410WMF	1.9	(0.9)
	26 ¹ / ₂	(673.0)	22 ³ / ₄	(577.0)	25 ³ / ₄	(654.0)	1050	FSP251WMF	FSP2510WMF	1.9	(0.9)
	30 ¹ / ₈	(765.2)	26 ³ / ₈	(669.9)	29 ³ / ₈	(746.1)	1250	FSP291WMF	FSP2910WMF	2.1	(1.0)
	33 ¹ / ₈	(841.4)	29 ³ / ₈	(746.1)	32 ³ / ₈	(822.3)	1350	FSP321WMF	FSP3210WMF	2.2	(1.0)
	35 ⁵ / ₈	(904.9)	31 ⁷ / ₈	(809.6)	34 ⁷ / ₈	(885.8)	1500		FSP3410WMF	2.3	(1.1)
	38 ³ / ₈	(974.7)	34 ⁵ / ₈	(879.5)	37 ⁵ / ₈	(955.7)	1600		FSP3710WMF	2.4	(1.1)
42 ¹ / ₈	(1070.0)	38 ³ / ₈	(974.7)	41 ³ / ₈	(1051.0)	1800		FSP4110WMF	2.5	(1.2)	
47 ³ / ₄	(1213.0)	44	(1117.0)	47	(1193.0)	2000		FSP4610WMF	2.7	(1.3)	
40 W/in² 304 SS (6.2 W/cm²)	10 ¹ / ₄	(260.0)	6 ¹ / ₂	(158.0)	9 ¹ / ₂	(241.0)	600	FSP91WKF		1.4	(0.7)
	11 ³ / ₄	(298.0)	8	(203.0)	11	(279.0)	750	FSP101WKF		1.4	(0.7)
	13 ³ / ₄	(349.0)	10	(254.0)	13	(330.0)	900	FSP121WKF	FSP1210WKF	1.5	(0.7)
	15	(381.0)	11 ¹ / ₄	(285.0)	14 ¹ / ₄	(362.0)	1000	FSP131WKF	FSP1310WKF	1.5	(0.7)
	17 ⁵ / ₈	(447.7)	13 ⁷ / ₈	(352.4)	16 ⁷ / ₈	(428.6)	1300	FSP161WKF	FSP1610WKF	1.6	(0.8)
	19 ¹ / ₄	(489.0)	15 ¹ / ₂	(393.0)	18 ¹ / ₂	(469.0)	1450	FSP181WKF	FSP1810WKF	1.7	(0.8)
	20 ³ / ₄	(527.0)	17	(431.0)	20	(508.0)	1600		FSP1910WKF	1.7	(0.8)
	23 ¹ / ₂	(597.0)	19 ³ / ₄	(501.0)	22 ³ / ₄	(577.0)	1800		FSP2210WKF	1.8	(0.9)
	25 ¹ / ₄	(641.0)	21 ¹ / ₂	(546.0)	24 ¹ / ₂	(622.0)	2000		FSP2410WKF	1.9	(0.9)
	26 ¹ / ₂	(673.0)	22 ³ / ₄	(577.0)	25 ³ / ₄	(654.0)	2100		FSP2510WKF	1.9	(0.9)
	30 ¹ / ₈	(765.2)	26 ³ / ₈	(669.9)	29 ³ / ₈	(746.1)	2500		FSP2910WKF	2.1	(1.0)
	33 ¹ / ₈	(841.4)	29 ³ / ₈	(746.1)	32 ³ / ₈	(822.3)	2700		FSP3210WKF	2.2	(1.0)
	35 ⁵ / ₈	(904.9)	31 ⁷ / ₈	(809.6)	34 ⁷ / ₈	(885.8)	3000		FSP3410WKF	2.3	(1.1)
	38 ³ / ₈	(974.7)	34 ⁵ / ₈	(879.4)	37 ⁵ / ₈	(955.7)	3200		FSP3710WKF	2.4	(1.1)
42 ¹ / ₈	(1070.0)	38 ³ / ₈	(974.7)	41 ³ / ₈	(1050.9)	3600		FSP4110WKF	2.5	(1.2)	
47 ³ / ₄	(1213.0)	44	(1117.0)	47	(1193.0)	4000		FSP4610WKF	2.7	(1.3)	

