

# IMPAC SERIES 600

Digital, modular pyrometer with exchangeable sensor heads for non-contact temperature measurement of various surfaces in different temperature ranges.



The Impac® Series 600 is a modular, digital pyrometer series that provides a customizable design with easy installation and maintenance. The long wavelength IN 600 is best suited for non-contact temperature measurement on non-metallic or coated metallic objects. The IS 600, IGA 600, and IGA 600/23 are short wavelengths digital pyrometers for measurements of metals, ceramics or graphite. The modular concept allows for various combinations of the system components. The standard configuration includes an electronic converter box, a sensor cable, and a removable sensor head to allow for easy exchange. Alternatively, each converter box can connect up to two sensor heads or up to two optional multi-sensor boxes with connections for up to four sensor heads each. To ensure maximum flexibility, the system allows for any combination of the available sensor heads, even with different wavelengths.

## PRODUCT HIGHLIGHTS

- Removeable sensor heads for easy exchange without the need to remove the complete sensor cable and without recalibration
- Connection of up to 8 sensor heads to one converter box (8 measuring points in one pyrometer system). If wanted, sensor heads with different wavelengths can be connected to the same converter box.
- Converter box available with or without display
- Optional communications: analog and/or RS-232/RS-485 and/or Profinet

## AT A GLANCE

### Temperature Ranges

IN 600 & IN 600-HT: -40 to 700 °C (MB 7)

IS 600: 550 to 1400 °C (MB 14)

650 to 1800 °C (MB 18)

700 to 2500 °C (MB 25)

IGA 600: 250 to 1200 °C (MB 12)

370 to 1800 °C (MB 18)

400 to 2500 °C (MB 25)

IGA 600/23: 100 to 1000 °C (MB 10)

150 to 1800 °C (MB 18)

### Spectral Range

Sensor Heads

IN 600 & IN 600-HT: 8 to 14 μm

IS 600: 0.7 to 1.1 μm

IGA 600: 1.45 to 1.8 μm

IGA 600/23: 2 to 2.6 μm

### Repeatability

IN 600 & IN 600-HT: 0.5% of measured °C value or 0.8 °C

IS 600, IGA 600 & IGA 600/23: 0.25% of measured °C + 1 °C

TECHNICAL DATA<sup>1</sup>

Measurement Specifications		
Temperature Ranges	IN 600 & IN 600-HT	-40 to 700 °C (-40 to 1292 °F), MB 7
	IS 600	550 to 1400 °C (1022 to 2552 °F), MB 14
		650 to 1800 °C (1202 to 3272 °F), MB 18
		700 to 2500 °C (1292 to 4532 °F), MB 25
	IGA 600	250 to 1200 °C (482 to 2192 °F), MB 12
		370 to 1800 °C (698 to 3272 °F), MB 18
		400 to 2500 °C (752 to 4532 °F), MB 25
	IGA 600/23	100 to 1000 °C (212 to 1832 °F), MB 10
150 to 1800 °C (302 to 3272 °F), MB 18		
Sub Range	Adjustable; min. range 51°C	
Spectral Ranges	IN 600 & IN 600-HT:	8 to 14 μm
	IS 600:	0.7 to 1.1 μm
	IGA 600:	1.45 to 1.8 μm
	IGA 600/23:	2 to 2.6 μm
Resolution	1/10°C (1/10°F, 1°F > 1000°F measuring temp.)	
Emissivity ε	10 to 120% adjustable in steps of 0.1%	
Measurement Uncertainty (ε = 1, t <sub>90</sub> = 1 s, T <sub>amb</sub> = 15 to 30°C)	IN 600 & IN 600-HT:	T = 0 to 700 °C: 0.7% oR or 1°C T = 0 to -20 °C: 2 °C T = -20 to -40 °C: 3 °C
	IS 600, IGA 600 & IGA 600/23:	0.5 % oR + 2 °C
	T <sub>k</sub> :	0.03% per °C or 0.05°C per °C (25°C ambient temperature)
Repeatability <sup>2</sup>	IN 600 & IN 600-HT:	0.5% of measured °C value or 0.8°C, whichever value is greater
	IS 600, IGA 600 & IGA 600/23:	0.25% of measured °C + 1 °C
Optics	Distance Ratio:	
	IN 600 & IN 600-HT:	2:1, 10:1, or 20:1
	IS 600:	65:1
	IGA 600 & IGA 600/23:	70:1

Electrical Specifications	
Power Supply	5 VDC (when connected via USB) or 10 to 30 VDC, ripple < 0.5 V, current consumption dependent on configuration
Load	Max 500 Ω
Output Impedance	18 Ω (for thermocouple or voltage output)

<sup>1</sup> The determination of the technical data of this pyrometer is carried out in accordance with VDI/VDE IEC TS 62942-2, the calibration / adjustment in accordance with VDI/VDE 3511, Part 4.4.

<sup>2</sup> The larger value is valid. The sensor head must be in constant ambient temperature for at least 15 minutes.

## TECHNICAL DATA CONTINUED

Environmental Specifications		
Protection Class	IP 65	
Max Ambient Temperature	Sensor heads (standard) IN 600, IS 600, IGA 600, IGA 600/23	0 to 80 °C (32 to 176 °F)
	Sensor head IN 600-HT	0 to 180 °C (32 to 356 °F)
	Converter box	0 to 65 °C (32 to 149 °F)
	Analog box	0 to 70 °C (32 to 158 °F)
Storage Temperature	Converter box	-20 to 70 °C (-4 to 158 °F), with non-condensing conditions.
	Sensor head, sensor cables, multi-sensor box, and analog box	-20 to 85 °C (-4 to 185 °F), with non-condensing conditions.
	IN 600-HT sensor heads	-20 to 180 °C (-4 to 356 °F), with non-condensing conditions.
Relative Humidity	10 to 95%, non-condensing	
Weight	Standard sensor heads	~40 g (~1.4 oz)
	IN 600-HT sensor head	~119 g (~4.2 oz)
	Direct USB connector	~70 g (~2.5 oz)
	Converter box with display	~395 g (~13.9 oz)
	Converter box without display	~380 g (~13.4 oz)
	Multi-sensor box	~260 g (~9.2 oz)
	Single analog box	~300 g (~10.6 oz)
	Multi analog box	~400 g (~14.1 oz)
Housing	Converter box: Aluminium	
	Sensor head: Stainless steel	

Interface and Communication	
Digital Interface	Optional: RS-232/RS-485 (switchable) or Profinet
Analog Output	Selectable: Linear current (0/4 to 20 mA), voltage (0 to 5 V) or thermocouple (type J or K)
Max Value Storage	Clear time: OFF, 0.1 s, 0.25 s, 0.5 s, 1 s, 5 s, 25 s, extern, auto
Response Time $t_{90}$	IN 600 & IN 600-HT: 180 ms, switchable (0.5 s, 1 s, 2 s, 5 s, 10 s, 30 s) IS 600, IGA 600 & IGA 600/23: 10 ms, switchable (50 ms, 250 ms, 1 s, 3 s, 10 s)
Output for Sensor Head Temp	10 mV/°C or 10 mV/°F
Relays Contact	Isolated relays contact, 50 VDC, 0.2A; temperature and hysteresis adjustable
Temp Display <sup>1</sup>	Color LCD, 262,000 colors

<sup>1</sup> Only for versions with integrated display

DIMENSIONS

Converter Box and Multi Analog Box

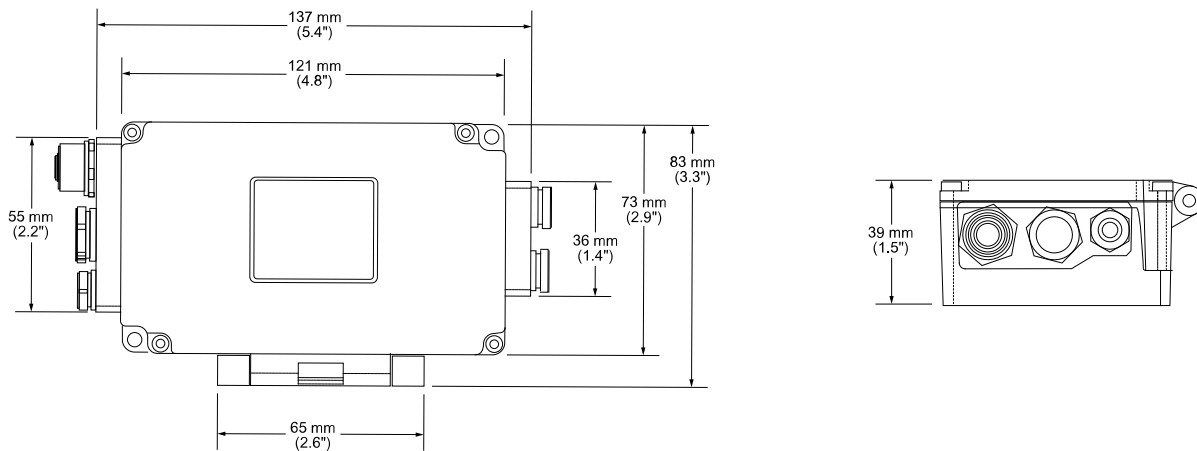

Sensor Head and Connector

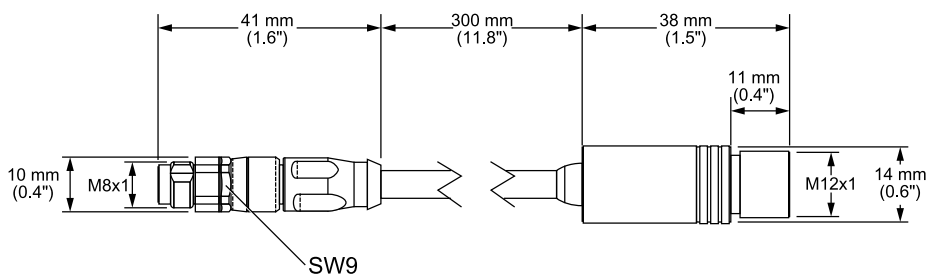

IN 600-HT Sensor Heads

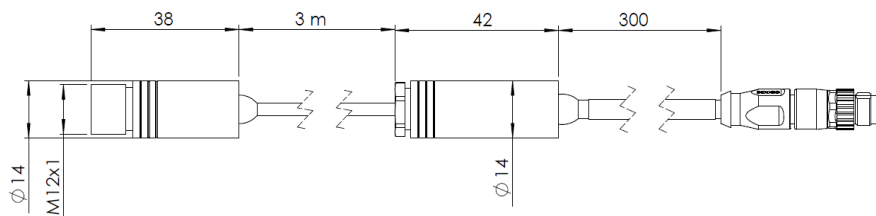

DIMENSIONS CONTINUED

Multi-Sensor Box

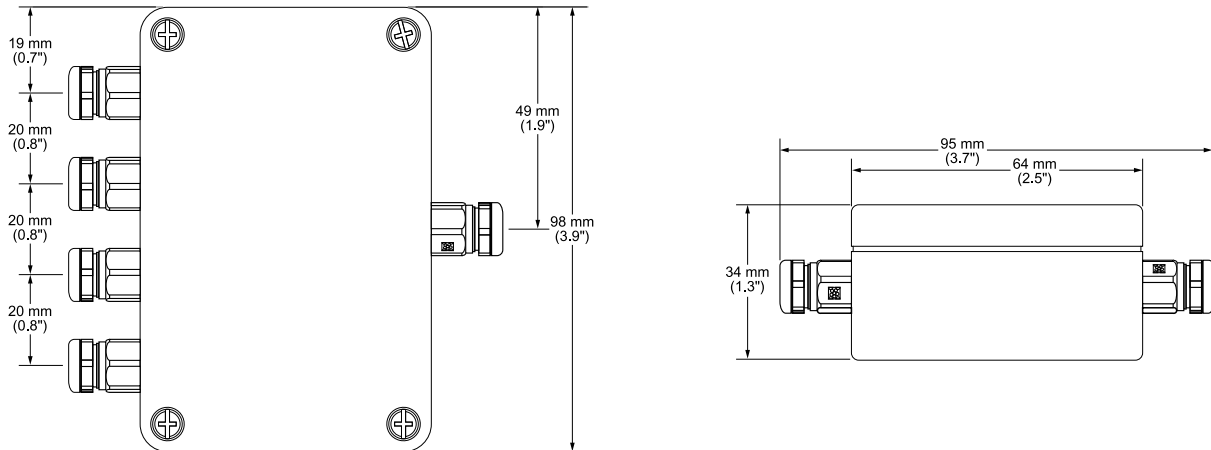

Single Analog Box

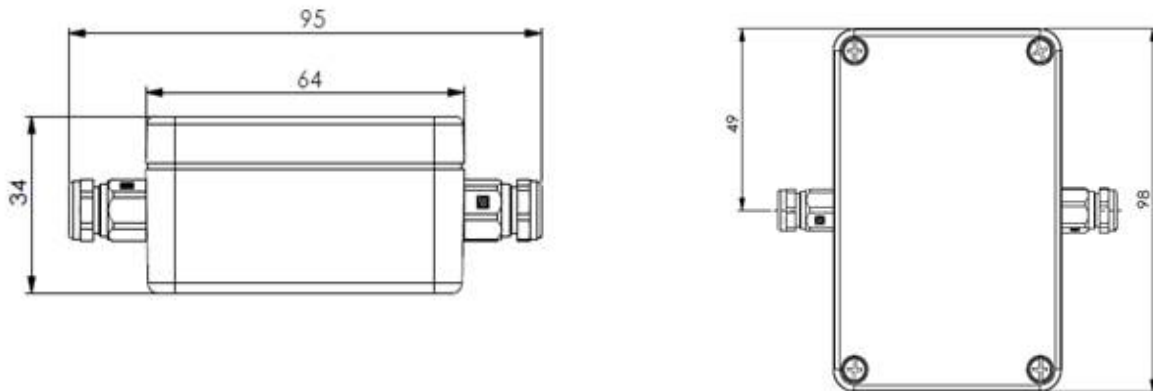

Direct USB Connector

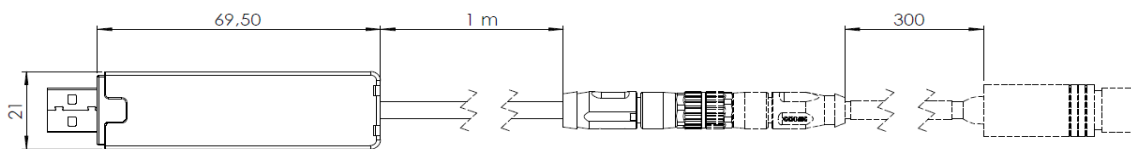

**OPTICS**

The IN 600 sensor heads are available with 3 different optics: 1N (2:1 distance ratio), 2N (10:1 distance ratio) and 3N (20:1 distance ratio).

The spot sizes at different measuring distances are shown in the tables below; intermediate values have to be interpolated.

Optics 1N, 2:1	
Measuring Distance a [mm]	Spot Size M [mm]
0	4.1
100	43.2
200	90
400	186
600	280
1000	470
2000	942

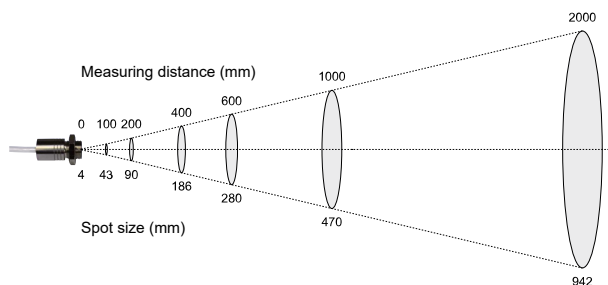

Optics 2N, 10:1	
Measuring Distance a [mm]	Spot Size M [mm]
0	4.1
70	3.3
100	6.6
200	17
400	38.1
600	59.3
1000	101.8
2000	207.4

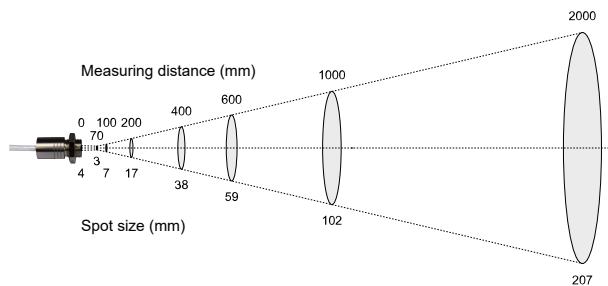

Optics 3N, 20:1	
Measuring Distance a [mm]	Spot Size M [mm]
0	4.1
100	7.4
200	10.6
400	19.8
600	31.8
1000	55.7
2000	115.2

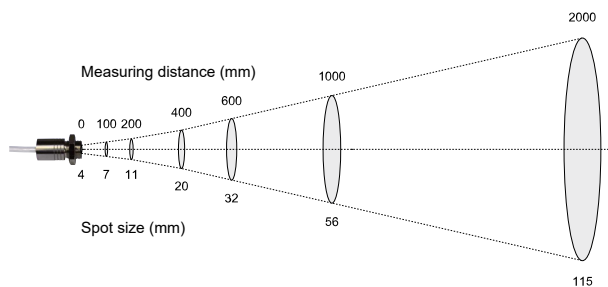

OPTICS CONTINUED

IS 600	
Measuring Distance a [mm]	Spot Size M [mm]
100	4.2
200	4.5
400	6.3
600	9.1
800	12.5

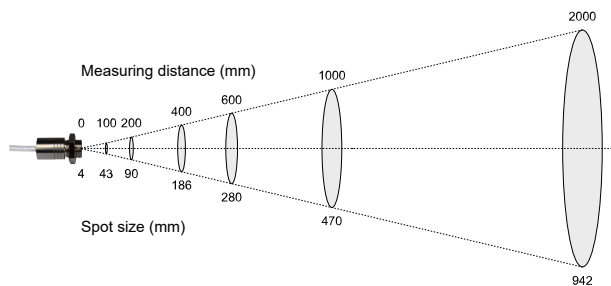

IGA 600 and IGA 600/23	
Measuring Distance a [mm]	Spot Size M [mm]
100	3.1
200	3.3
400	5.6
600	8.8
800	13

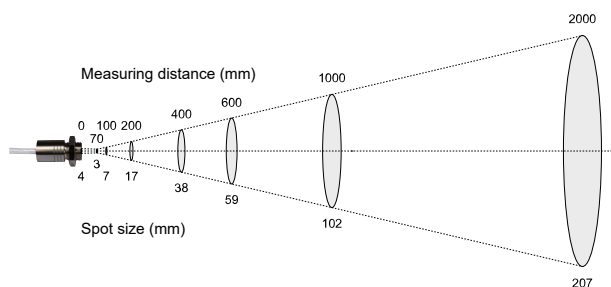

REFERENCE NUMBERS

Converter Box	
PN	Description
3 917 010	ICB 600 converter box with display, no digital interface
3 917 020	ICB 600-RS converter box with display, RS-232/RS-485
3 917 040	ICB 600-PN converter box with display, Profinet
3 917 080	ICB 600-N converter box without display, no digital interface
3 917 090	ICB 600-N-RS converter box without display, RS-232/RS-485
3 917 110	ICB 600-N-PN converter box without display, Profinet
3 917 160	ICB-A converter box, single analog
3 917 170	ICB-8A converter box, multi analog

Sensor Heads	
PN	Description
3 917 200	IN 600, MB 7, 8 to 14 µm, -40 to 700 °C, optics 1N (2:1)
3 917 210	IN 600, MB 7, 8 to 14 µm, -40 to 700 °C, optics 2N (10:1)
3 917 220	IN 600, MB 7, 8 to 14 µm, -40 to 700 °C, optics 3N (20:1)
3 917 230	IN 600-HT, -40 to 700 °C, 8 to 14 µm, optics 1N (2:1)
3 917 240	IN 600-HT, -40 to 700 °C, 8 to 14 µm, optics 2N (10:1)
3 917 250	IN 600-HT, -40 to 700 °C, 8 to 14 µm, optics 3N (20:1)
3 917 260	IS 600, 550 to 1400 °C, 0.7 to 1.1 µm, optics 1S
3 917 270	IS 600, 650 to 1800 °C, 0.7 to 1.1 µm, optics 1S
3 917 280	IS 600, 700 to 2500 °C, 0.7 to 1.1 µm, optics 1S
3 917 290	IGA 600, 250 to 1200 °C, 1.45 to 1.8 µm, optics 1S
3 917 300	IGA 600, 370 to 1800 °C, 1.45 to 1.8 µm, optics 1S
3 917 310	IGA 600, 400 to 2500 °C, 1.45 to 1.8 µm, optics 1S
3 917 320	IGA 600/23, 100 to 1000 °C, 2 to 2.6 µm, optics 1S
3 917 330	IGA 600/23, 150 to 1800 °C, 2 to 2.6 µm, optics 1S

Other	
PN	Description
3 917 150	Multi-sensor box

Sensor and Extension Cables	
PN	Description
3 921 200	Sensor cable, with connector, 3 m
3 921 210	Sensor cable, with connector, 15 m
3 921 220	Extension cable, with connector, 15 m
3 921 230	Sensor cable, w/o connector, 1 m
3 921 240	Sensor cable, w/o connector, 3 m
3 921 250	Sensor cable, w/o connector, 15 m

## REFERENCE NUMBERS (CONTINUED)

Electrical Connection Cables	
PN	Description
3 821 010	Electrical connection cable, 2 m, 10-wire, with digital connection (1 m)
3 821 980	Electrical connection cable, 15 m, 10-wire, with digital connection (1 m)
3 921 260	Electrical connection cable, 2 m, for power supply and thermocouple output
3 921 270	Electrical connection cable, 2 m, 7-wire, analog out only
3 921 280	Electrical connection cable, 15 m, 7-wire, analog out only
3 921 300	Electrical connection cable, 2 m, 10-wire, analog out
3 921 310	Electrical connection cable, 15 m, 10-wire, analog out
3 921 320	Electrical connection cable, 2 m, 12-wire, analog out
3 921 330	Electrical connection cable, 15 m, 12-wire, analog out
3 921 290	Micro USB 2.0 cable, 1m

Other Accessories	
PN	Description
3 834 370	Fixed mounting angle (for sensor head or air purge with sensor head 10:1)
3 834 380	Adjustable mounting angle (for sensor head or air purge with sensor head 10:1)
3 835 800	DIN rail mount adapter for converter box
3 835 810	Air purge (for sensor head 10:1 and 20:1)
3 835 820	Air purge (for sensor head 2:1)
3 835 840	Cooling jacket for optical head, with air purge, cooling hose 0.75 m
3 835 850	Cooling jacket for optical head, with air purge, cooling hose 2.5 m
3 835 830	90° mirror (only for sensor head 10:1)
3 890 560	DA 6000-N: LED digital display with digital input RS-232 and possibility for pyrometer parameter settings
3 890 570	DA 6000-N digital display, to allow adjustment of pyrometer through RS-485 interface
3 826 500	HT 6000: portable battery driven indicator and instrument for pyrometer parameter settings; RS-232 / RS-485
3 852 290	Power supply NG DC for DIN rail mounting; 100 to 240 VAC ⇒ 24 VDC, 1 A



## **ABOUT ADVANCED ENERGY**

Advanced Energy (AE) has devoted more than three decades to perfecting power for its global customers. AE designs and manufactures highly engineered, precision power conversion, measurement and control solutions for mission-critical applications and processes.

Our products enable customer innovation in complex applications for a wide range of industries including semiconductor equipment, industrial, manufacturing, telecommunications, data center computing, and medical. With deep applications know-how and responsive service and support across the globe, we build collaborative partnerships to meet rapid technological developments, propel growth for our customers, and innovate the future of power.

**PRECISION | POWER | PERFORMANCE**

For international contact information,  
visit [advancedenergy.com](http://advancedenergy.com).

[sales.support@aei.com](mailto:sales.support@aei.com)  
+1 970 221 0108

---

Specifications are subject to change without notice. Not responsible for errors or omissions. ©2021 Advanced Energy Industries, Inc. All rights reserved. Advanced Energy®, Impac®, and AE® are U.S. trademarks of Advanced Energy Industries, Inc.